



EL 8000 Main Entrance

Η ELVIAL δημιούργησε ένα στιβαρό θερμομονωτικό σύστημα εισόδου, το οποίο συνίσταται για εισόδους πολυκατοικιών και γενικά για βαριά και συχνή χρήση, αλλά και για δημόσια κτίρια.

Το σύστημα εισόδου el 8000 ενδείκνυται για μεγάλα ανοίγματα και σας δίνει τη δυνατότητα να κατασκευάσετε όλες τις τυπολογίες εισόδου. Επιπλέον, το νέο σύστημα της ELVIAL υπερέχει χάρη στην άριστη στεγανότητα που επιτυγχάνεται με τη χρήση αυτόματων αεροφρακτών ή τοποθετώντας κατωκάσι.

Ακόμη, παρουσιάζει αυξημένη αντοχή καθώς δέχεται μεντεσέδες βαρέως τύπου (εμφανείς και κρυφούς) και διακρίνεται σε θέματα πρακτικότητας και λειτουργικότητας χάρη στη πληθώρα αυτοματισμών που μπορεί να δεχθεί (αυτόματο άνοιγμα με ηλεκτρομηχανικό μηχανισμό, σύστημα αναγνώρισης δακτυλικού αποτυπώματος, κάρτας, κωδικού, κτλ.).

EL 8000 Main Entrance

ELVIAL has developed a firm thermal insulating system for main entrances, which is recommended in general for frequent use such as buildings entrances, but also for public buildings' entrances.

The entrance system el 8000 is advisable for big openings and gives you the possibility to construct all kinds of entrances. Moreover, ELVIAL's new system offers excellent insulation that is achieved through the use of automatic airlocks or by placing bottom frames.

Furthermore, it is highly resistant thanks to the use of heavily type hinges (visible and hidden) and it is remarkable in terms of functionalism thanks to the variety of automatism that can be adapted (automatic opening with electro mechanism, system of finger imprint identification, card, code etc.).



DIN EN ISO 9001 : 2000

ΠΕΡΙΕΧΟΜΕΝΑ/ CONTENTS

EL 8000 Main Entrance

	Σελ./Page
• Τεχνικά χαρακτηριστικά / Technical Characteristics	03
• Συνοπτικά προφίλ / Synoptic profiles	05
• Προφίλ / Profiles	09
• Τομές / Sections	17
• Κοπές / Cuttings	31
• Εξαρτήματα / Accessories	41
• Κατεργασίες / Constructions' Specifications	55
• 3d's	73



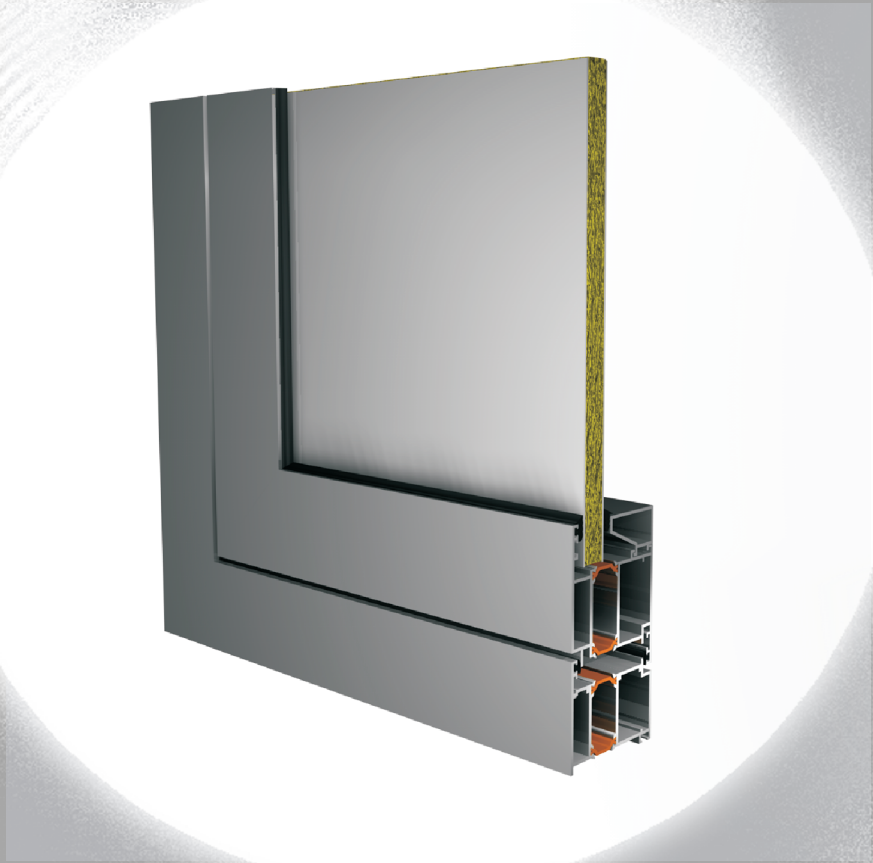



Τα βάρη που αναφέρονται στον κατάλογο είναι θεωρητικά και αφορούν άβαφο και ατύλιχτο προϊόν. Οποιοσδήποτε αποκλίσεις $\pm 10\%$ είναι εντός των προδιαγραφών και θεωρούνται αποδεκτές.

IMPORTANT NOTICE

The weights mentioned in this catalogue are theoretical. They do not include painting and packaging. Any declination $\pm 10\%$ is considered valid and acceptable according to specifications.

EL - 8000







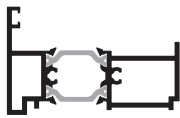
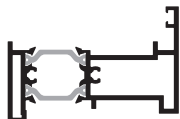

■	Συνοπτικά Προφίλ - Synoptic Profiles
■	Προφίλ - Profiles
■	Τομές - Sections
■	Κοπές - Cuttings
■	Εξαρτήματα - Accessories
■	Κατεργασίες - Constructions' Specifications
■	3d's

ΟΛΑ ΤΑ ΠΡΟΦΙΛ ΕΜΦΑΝΙΖΟΝΤΑΙ ΣΕ ΚΛΙΜΑΚΑ 1/3, ΕΚΤΟΣ ΑΠΟ ΑΥΤΑ ΠΟΥ ΑΝΑΓΡΑΦΟΥΝ ΚΑΤΙ ΑΛΛΟ

ALL PROFILES ARE IN 1/3 SCALE. THOSE THAT HAVE A DIFFERENT SCALE HAVE THE PERCENTAGE SIGNED NEXT TO THEM







ΚΩΔΙΚΟΣ	Περιγραφή	ΜΗΚΟΣ / LENGTH	ΔΙΑΣΤΑΣΕΙΣ / DIMENSIONS	ΤΕΜ./ΔΕΜΑ / PCS/BUNDLE	ΡΟΠΗ ΑΔΡΑΝΕΙΑΣ / MOMENT OF INERTIA	ΣΕΛΙΔΑ / PAGE
EL 8001	Κάσα για είσοδο ανοιγόμενη προς τα μέσα Frame for an inwards opening entrance	6m	ΠΛΑΤΟΣ / WIDTH 77mm ΥΨΟΣ / HEIGHT 67,5mm ΠΕΡΙΜΕΤΡΟΣ / PERIMETER 355mm	2	$I_x = 28,57 \text{ cm}^4$ $I_y = 54,57 \text{ cm}^4$	
EL 8002	Κάσα για είσοδο ανοιγόμενη προς τα έξω Frame for an outwards opening entrance	6m	ΠΛΑΤΟΣ / WIDTH 77mm ΥΨΟΣ / HEIGHT 67,5mm ΠΕΡΙΜΕΤΡΟΣ / PERIMETER 365mm	2	$I_x = 28,27 \text{ cm}^4$ $I_y = 57,39 \text{ cm}^4$	
EL 8003	Κάσα για σταθερές κατασκευές Frame for fixed constructions	6m	ΠΛΑΤΟΣ / WIDTH 77mm ΥΨΟΣ / HEIGHT 67,5mm ΠΕΡΙΜΕΤΡΟΣ / PERIMETER 397mm	2	$I_x = 20,29 \text{ cm}^4$ $I_y = 52,24 \text{ cm}^4$	
EL 8011	Φύλλο εισόδου ανοιγόμενης προς τα μέσα Sash for an inwards opening entrance	6,5m	ΠΛΑΤΟΣ / WIDTH 77mm ΥΨΟΣ / HEIGHT 98,2mm ΠΕΡΙΜΕΤΡΟΣ / PERIMETER 493mm	2	$I_x = 50,79 \text{ cm}^4$ $I_y = 69,59 \text{ cm}^4$	
EL 8022	Φύλλο εισόδου ανοιγόμενης προς τα έξω Sash for an outwards opening entrance	6,5m	ΠΛΑΤΟΣ / WIDTH 77mm ΥΨΟΣ / HEIGHT 98,2mm ΠΕΡΙΜΕΤΡΟΣ / PERIMETER 474mm	2	$I_x = 49,94 \text{ cm}^4$ $I_y = 64,25 \text{ cm}^4$	
EL 8013	Φύλλο ανοιγόμενης προς τα μέσα Sash for an inwards opening entrance	6,5m	ΠΛΑΤΟΣ / WIDTH 74,2mm ΥΨΟΣ / HEIGHT 74,2mm ΠΕΡΙΜΕΤΡΟΣ / PERIMETER 392mm	2	$I_x = 36,64 \text{ cm}^4$ $I_y = 54,71 \text{ cm}^4$	
EL 8041	Ίσιο Τ-σχήμα Linear T-shaped profile	6m	ΠΛΑΤΟΣ / WIDTH 77mm ΥΨΟΣ / HEIGHT 91,5mm ΠΕΡΙΜΕΤΡΟΣ / PERIMETER 472mm	2	$I_x = 30,58 \text{ cm}^4$ $I_y = 57,24 \text{ cm}^4$	

ΚΩΔΙΚΟΣ	Περιγραφή	ΜΗΚΟΣ / LENGTH	ΔΙΑΣΤΑΣΕΙΣ / DIMENSIONS	ΤΕΜ./ΔΕΜΑ / PCS./BUNDLE	ΡΟΠΗ ΑΔΡΑΝΕΙΑΣ / MOMENT OF INERTIA	ΣΕΛΙΔΑ / PAGE
EL 8061	Μπινί για είσοδο ανοιγόμενη προς τα μέσα Adjoining profile for an inwards opening entrance 	6m ΒΑΡΟΣ / WEIGHT 1464gr/m	ΠΛΑΤΟΣ / WIDTH 68,6mm ΥΨΟΣ / HEIGHT 43mm ΠΕΡΙΜΕΤΡΟΣ / PERIMETER 272mm	2		
EL 8062	Μπινί για είσοδο ανοιγόμενη προς τα έξω Adjoining profile for an outwards opening entrance 	6m ΒΑΡΟΣ / WEIGHT 1562gr/m	ΠΛΑΤΟΣ / WIDTH 68,6mm ΥΨΟΣ / HEIGHT 43mm ΠΕΡΙΜΕΤΡΟΣ / PERIMETER 294mm	2		
EL 8075	Κατωκάσι είσοδου για χρήση ανεμοφράκτη Entrance threshold for windshield  100%	6 m* (1,2) ΒΑΡΟΣ / WEIGHT 259gr/m	ΠΛΑΤΟΣ / WIDTH 35mm ΥΨΟΣ / HEIGHT 4mm ΠΕΡΙΜΕΤΡΟΣ / PERIMETER 78mm	10		
EL 8076	Κατωκάσι για είσοδο ανοιγ. προς τα μέσα Threshold for inwards opening entrance  50%	6 m* (1,2) ΒΑΡΟΣ / WEIGHT 775gr/m	ΠΛΑΤΟΣ / WIDTH 68,6mm ΥΨΟΣ / HEIGHT 14mm ΠΕΡΙΜΕΤΡΟΣ / PERIMETER 190mm	5		
EL 8077	Κατωκάσι για είσοδο ανοιγ. προς τα έξω Threshold for outwards opening entrance  50%	6 m* (1,2) ΒΑΡΟΣ / WEIGHT 745gr/m	ΠΛΑΤΟΣ / WIDTH 60,2mm ΥΨΟΣ / HEIGHT 14mm ΠΕΡΙΜΕΤΡΟΣ / PERIMETER 190mm	5		
EL 8070	Πρόσθετο φύλλο για χρήση ανεμοφράκτη Sash's additional profile for use of windshield  100%	6 m* (1,2) ΒΑΡΟΣ / WEIGHT 276gr/m	ΠΛΑΤΟΣ / WIDTH 19,6mm ΥΨΟΣ / HEIGHT 23,7mm ΠΕΡΙΜΕΤΡΟΣ / PERIMETER 105mm	10		
EL 8071	Πρόσθετο φύλλο για χρήση κατωκασιού Sash's additional profile for use of threshold  100%	6m* (1,2) ΒΑΡΟΣ / WEIGHT 24 1gr/m	ΠΛΑΤΟΣ / WIDTH 20,5mm ΥΨΟΣ / HEIGHT 11,5mm ΠΕΡΙΜΕΤΡΟΣ / PERIMETER 86mm	10		

* Σε όλα τα χρώματα πλην του λευκού, διατίθεται και σε μήκος 1,2μ

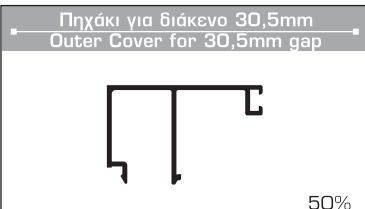
ΟΛΑ ΤΑ ΠΡΟΦΙΛ ΕΜΦΑΝΙΖΟΝΤΑΙ ΣΕ ΚΛΙΜΑΚΑ 1/3, ΕΚΤΟΣ ΑΠΟ ΑΥΤΑ ΠΟΥ ΑΝΑΓΡΑΦΟΥΝ ΚΑΤΙ ΑΛΛΟ

ALL PROFILES ARE IN 1/3 SCALE. THOSE THAT HAVE A DIFFERENT SCALE HAVE THE PERCENTAGE SIGNED NEXT TO THEM

ΚΩΔΙΚΟΣ	ΕΝΩΤΙΚΟ ΠΡΟΦΙΛ ΓΙΑ ΚΑΣΕΣ Joining profile for frames	ΜΗΚΟΣ / LENGTH	ΔΙΑΣΤΑΣΕΙΣ DIMENSIONS	ΤΕΜ./ΔΕΜΑ PCS/BUNDLE	ΡΟΠΗ ΑΔΡΑΝΕΙΑΣ MOMENT OF INERTIA	ΣΕΛΙΔΑ PAGE
EL 8034	 50%	6 m ΒΑΡΟΣ / WEIGHT 108gr/m	ΠΛΑΤΟΣ / WIDTH 6,5mm ΥΨΟΣ / HEIGHT 16,1mm ΠΕΡΙΜΕΤΡΟΣ/ PERIMETER 62mm	10		
EL 6772	Αρμολάιτρο Outer Cover  40%	6m ΒΑΡΟΣ / WEIGHT 284gr/m	ΠΛΑΤΟΣ / WIDTH 9,1mm ΥΨΟΣ / HEIGHT 50mm ΠΕΡΙΜΕΤΡΟΣ/ PERIMETER 172mm	10		
EL 2080	Αρμολάιτρο Outer Cover  50%	6m ΒΑΡΟΣ / WEIGHT 338gr/m	ΠΛΑΤΟΣ / WIDTH 42,5mm ΥΨΟΣ / HEIGHT 42,5mm ΠΕΡΙΜΕΤΡΟΣ/ PERIMETER 191mm	10		
EL 5683	Πηχάκι για διάκενο 30,5mm Outer Cover for 30,5mm gap  50%	6m ΒΑΡΟΣ / WEIGHT 379gr/m	ΠΛΑΤΟΣ / WIDTH 41,2 ΥΨΟΣ / HEIGHT 21,8 ΠΕΡΙΜΕΤΡΟΣ/ PERIMETER 217	12		
EL 8091	Πηχάκι για διάκενο 33mm Outer Cover for 33mm gap  50%	6gr/m ΒΑΡΟΣ / WEIGHT 651gr/m	ΠΛΑΤΟΣ / WIDTH 38,7 ΥΨΟΣ / HEIGHT 23,7 ΠΕΡΙΜΕΤΡΟΣ/ PERIMETER 141	10		
EL 2005A	Πηχάκι για διάκενο 37,7mm Outer Cover for 37,7mm gap  50%	6gr/m ΒΑΡΟΣ / WEIGHT 353gr/m	ΠΛΑΤΟΣ / WIDTH 34 ΥΨΟΣ / HEIGHT 21,8 ΠΕΡΙΜΕΤΡΟΣ/ PERIMETER 206	12		
EL 2005B	Πηχάκι για διάκενο 42,7mm Outer Cover for 42,7mm gap  50%	6m ΒΑΡΟΣ / WEIGHT 321gr/m	ΠΛΑΤΟΣ / WIDTH 29 ΥΨΟΣ / HEIGHT 21,8 ΠΕΡΙΜΕΤΡΟΣ/ PERIMETER 194	12		
EL 5591	Πηχάκι για διάκενο 45,3mm Outer Cover for 45,3mm gap  50%	6gr/m ΒΑΡΟΣ / WEIGHT 458gr/m	ΠΛΑΤΟΣ / WIDTH 26,4 ΥΨΟΣ / HEIGHT 21,8 ΠΕΡΙΜΕΤΡΟΣ/ PERIMETER 113			

EL - 8000

■	Συνοπτικά προφίλ - Synoptic profiles
■	Προφίλ - Profiles
■	Τομές - Sections
■	Κοπές - Cuttings
■	Εξαρτήματα - Accessories
■	Κατεργασίες - Constructions' Specifications
■	3d's

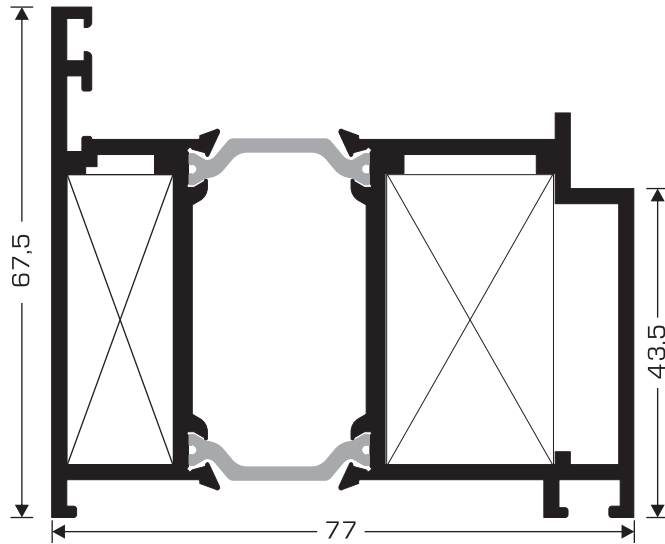

EL 8001	ΚΑΣΑ ΓΙΑ ΕΙΣΟΔΟ ΑΝΟΙΓΟΜΕΝΗ ΠΡΟΣ ΤΑ ΜΕΣΑ FRAME FOR AN INWARDS OPENING ENTRANCE
Βάρος - Weight 2 153 (gr/m)	Περίμετρος - Perimeter 355 mm
Γωνίες Συνδέσεως Joint Corners	805 1.140 805 1.220
Ροπή αδράνειας Moment of Inertia	$I_x = 28,57 \text{ cm}^4$ $I_y = 54,57 \text{ cm}^4$

ΜΗΚΟΣ / LENGTH 6m
TEM/ΔΕΜΑ PCS/BUNDLE 2

EL 8002	ΚΑΣΑ ΓΙΑ ΕΙΣΟΔΟ ΑΝΟΙΓΟΜΕΝΗ ΠΡΟΣ ΤΑ ΕΞΩ FRAME FOR AN OUTWARDS OPENING ENTRANCE
Βάρος - Weight 2 165 (gr/m)	Περίμετρος - Perimeter 365 mm
Γωνίες Συνδέσεως Joint Corners	805 1.320 5430.110
Ροπή αδράνειας Moment of Inertia	$I_x = 28,27 \text{ cm}^4$ $I_y = 57,39 \text{ cm}^4$

ΜΗΚΟΣ / LENGTH 6m
TEM/ΔΕΜΑ PCS/BUNDLE 2

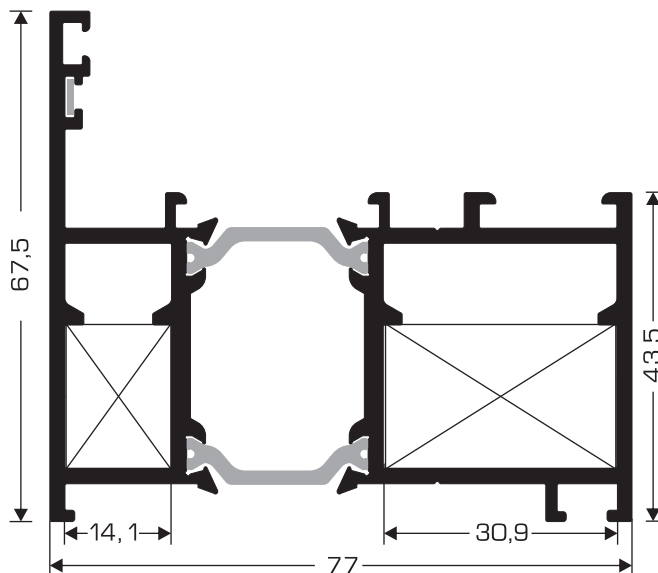
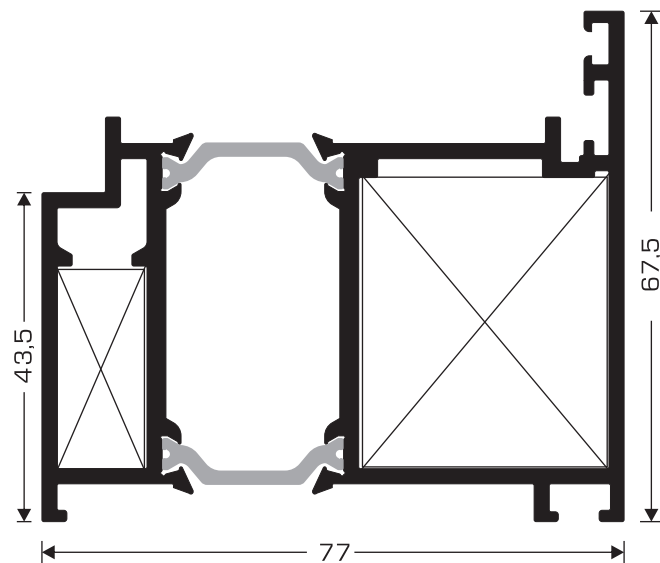

EL 8003	ΚΑΣΑ ΓΙΑ ΣΤΑΘΕΡΕΣ ΚΑΤΑΣΚΕΥΕΣ FRAME FOR FIXED CONSTRUCTIONS
Βάρος - Weight 2 009 (gr/m)	Περίμετρος - Perimeter 397 mm
Γωνίες Συνδέσεως Joint Corners	5408.140 5408.300
Γωνίες Επιπεδότητας Joint Corners	GE 120 1 INOX
Ροπή αδράνειας Moment of Inertia	$I_x = 20,29 \text{ cm}^4$ $I_y = 52,24 \text{ cm}^4$

ΜΗΚΟΣ / LENGTH 6m
TEM/ΔΕΜΑ PCS/BUNDLE 2

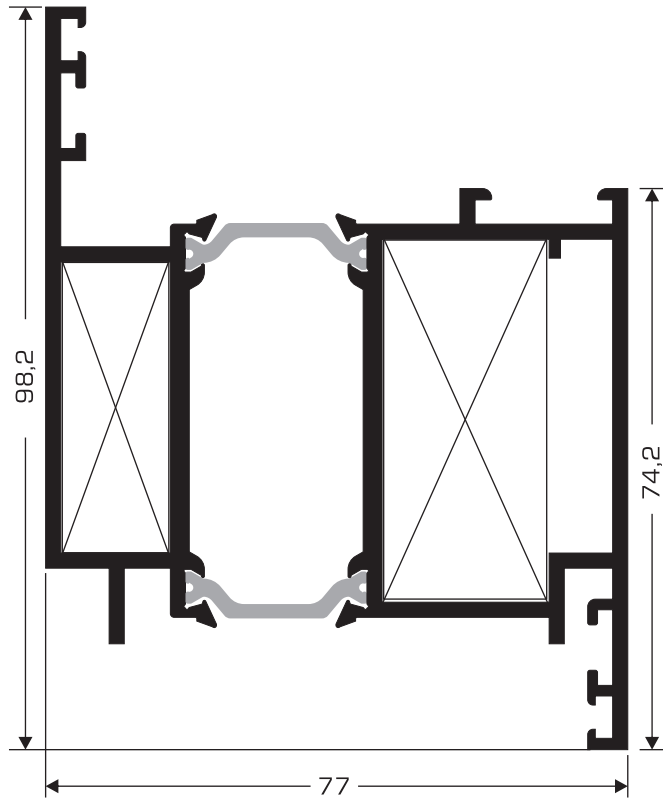

EL 8011	ΦΥΛΛΟ ΕΙΣΟΔΟΥ ΑΝΟΙΓΟΜΕΝΗΣ ΠΡΟΣ ΤΑ ΜΕΣΑ SASH FOR AN INWARDS OPENING ENTRANCE
Βάρος - Weight 25 14 (gr/m)	Περίμετρος - Perimeter 493 mm
Γωνίες Συνδέσεως Joint Corners	805 1. 140 8052.220
Ροπή αδράνειας Moment of Inertia	$I_x = 50,79 \text{ cm}^4$ $I_y = 69,59 \text{ cm}^4$

ΜΗΚΟΣ / LENGTH 6,5m
ΤΕΜ/ΔΕΜΑ PCS/BUNDLE 2

EL 8022	ΦΥΛΛΟ ΕΙΣΟΔΟΥ ΑΝΟΙΓΟΜΕΝΗΣ ΠΡΟΣ ΤΑ ΕΞΩ SASH FOR AN OUTWARDS OPENING ENTRANCE
Βάρος - Weight 2460 (gr/m)	Περίμετρος - Perimeter 474 mm
Γωνίες Συνδέσεως Joint Corners	805 1. 140 8052.220
Ροπή αδράνειας Moment of Inertia	$I_x = 49,94 \text{ cm}^4$ $I_y = 64,25 \text{ cm}^4$

ΜΗΚΟΣ / LENGTH 6,5m
ΤΕΜ/ΔΕΜΑ PCS/BUNDLE 2

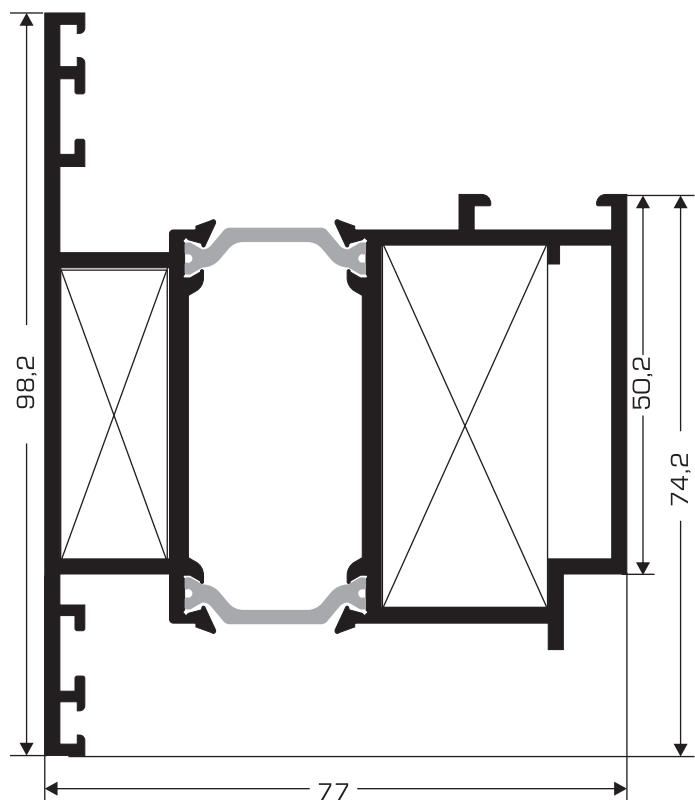

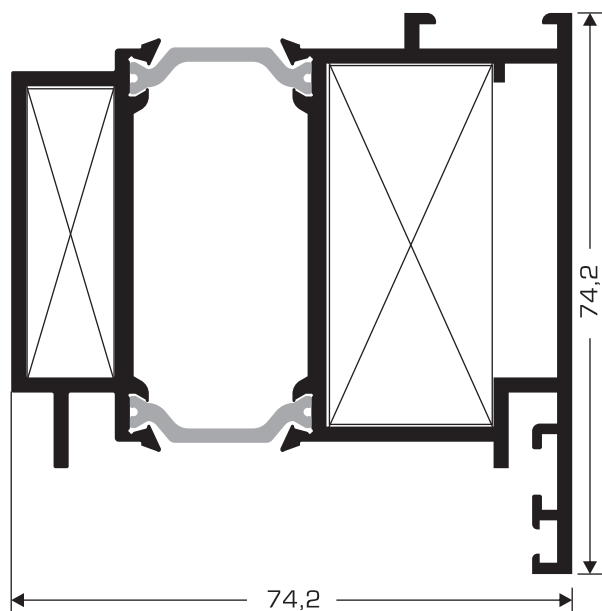

EL 8013	ΦΥΛΛΟ ΓΙΑ ΕΙΣΟΔΟ ΑΝΟΙΓΟΜΕΝΗ ΠΡΟΣ ΤΑ ΜΕΣΑ SASH FOR AN INWARDS OPENING ENTRANCE
Βάρος - Weight 2253 (gr/m)	Περίμετρος - Perimeter 392 mm
Γωνίες Συνδέσεως Joint Corners	805 1.110 8052.220
Ροπή αδράνειας Moment of Inertia	$I_x = 36,64 \text{ cm}^4$ $I_y = 54,71 \text{ cm}^4$

ΜΗΚΟΣ / LENGTH 6,5m
ΤΕΜ/ΔΕΜΑ PCS/BUNDLE 2

EL 8041	ΙΣΙΟ ΤΑΦ LINEAR T-SHAPED PROFILE
Βάρος - Weight 2228(gr/m)	Περίμετρος - Perimeter 472 mm
Ροπή αδράνειας Moment of Inertia	$I_x = 30,58 \text{ cm}^4$ $I_y = 57,24 \text{ cm}^4$

ΜΗΚΟΣ / LENGTH 6m
ΤΕΜ/ΔΕΜΑ PCS/BUNDLE 2

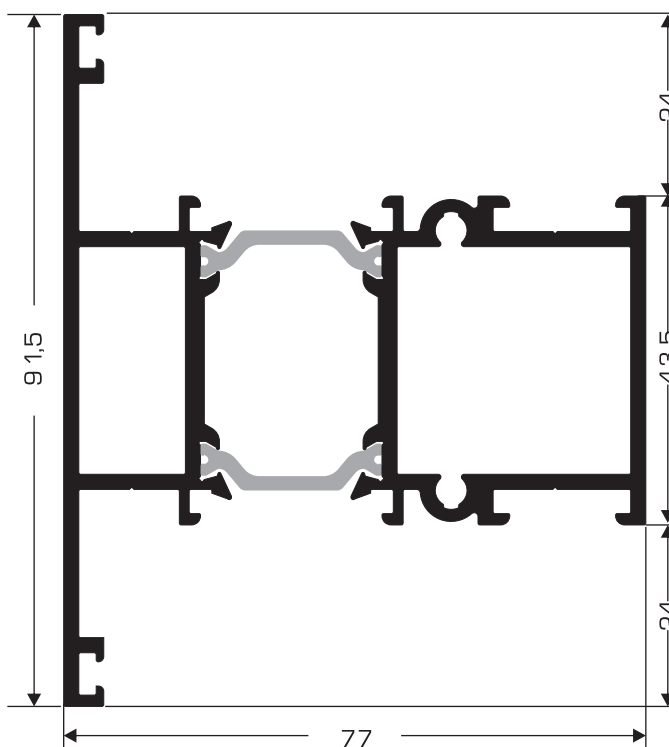

EL 8061	ΜΠΙΝΙ ΓΙΑ ΕΙΣΟΔΟ ΑΝΟΙΓΟΜΕΝΗ ΠΡΟΣ ΤΑ ΜΕΣΑ ADJOINING PROFILE FOR AN INWARDS OPENING ENTRANCE
Βάρος - Weight 1464 (gr/m)	Περίμετρος - Perimeter 272 mm
Συνεργάζεται με Combines with	P.806 1L, P.806 1R P.806 1LWS, P.806 1RWS

ΜΗΚΟΣ / LENGTH 6m
ΤΕΜ/ΔΕΜΑ PCS/BUNDLE 2

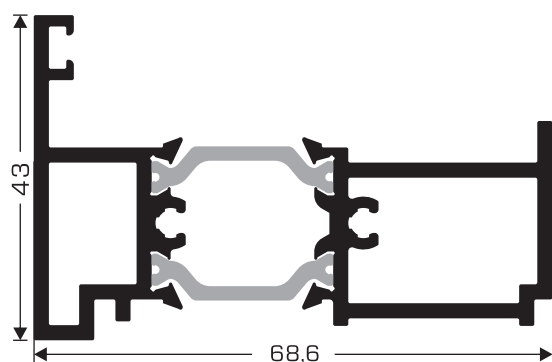

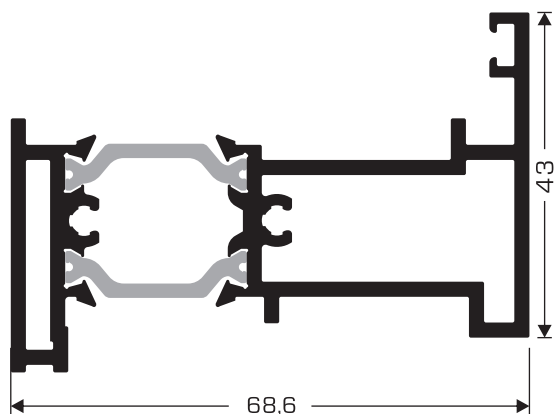

EL 8062	ΜΠΙΝΙ ΓΙΑ ΕΙΣΟΔΟ ΑΝΟΙΓΟΜΕΝΗ ΠΡΟΣ ΤΑ ΕΞΩ ADJOINING PROFILE FOR AN OUTWARDS OPENING ENTRANCE
Βάρος - Weight 1562 (gr/m)	Περίμετρος - Perimeter 294m
Συνεργάζεται με Combines with	P.8062L, P.8062R P.8062LWS, P.8062RWS

ΜΗΚΟΣ / LENGTH 6m
TEM/ΔΕΜΑ PCS/BUNDLE 2

EL 8075	ΚΑΤΩΚΑΣΙ ΕΙΣΟΔΟΥ ΓΙΑ ΧΡΗΣΗ ΑΝΕΜΟΦΡΑΚΤΗ ENTRANCE THRESHOLD FOR WINDSIELD
Βάρος - Weight 259 (gr/m)	Περίμετρος - Perimeter 78m

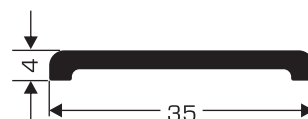

ΣΕ ΟΛΑ ΤΑ ΧΡΩΜΑΤΑ
ΠΛΗΝ ΤΟΥ ΛΕΥΚΟΥ
ΔΙΑΤΙΘΕΤΑΙ ΚΑΙ ΣΕ ΜΗΚΟΣ 1,2m
THE ITEM CAN ALSO BE
SUPPLIED IN 1,2m WIDTH IN ALL
COLORATIONS APART WHITE

ΜΗΚΟΣ / LENGTH 6m
TEM/ΔΕΜΑ PCS/BUNDLE 10



EL 8076	ΚΑΤΩΚΑΣΙ ΓΙΑ ΕΙΣΟΔΟ ΑΝΟΙΓΟΜΕΝΗ ΠΡΟΣ ΤΑ ΜΕΣΑ ENTRANCE THRESHOLD FOR INWARDS OPENING ENTRANCE
Βάρος - Weight 775 (gr/m)	Περίμετρος - Perimeter 190m
Συνεργάζεται με Combines with	ΤΗΝ ΤΑΠΑ P.8076

ΣΕ ΟΛΑ ΤΑ ΧΡΩΜΑΤΑ
ΠΛΗΝ ΤΟΥ ΛΕΥΚΟΥ
ΔΙΑΤΙΘΕΤΑΙ ΚΑΙ ΣΕ ΜΗΚΟΣ 1,2m
THE ITEM CAN ALSO BE
SUPPLIED IN 1,2m WIDTH IN ALL
COLORATIONS APART WHITE

ΜΗΚΟΣ / LENGTH 6m
TEM/ΔΕΜΑ PCS/BUNDLE 5

EL 8077	ΚΑΤΩΚΑΣΙ ΓΙΑ ΕΙΣΟΔΟ ΑΝΟΙΓΟΜΕΝΗ ΠΡΟΣ ΤΑ ΜΕΣΑ ENTRANCE THRESHOLD FOR OUTWARDS OPENING ENTRANCE
Βάρος - Weight 745 (gr/m)	Περίμετρος - Perimeter 190m
Συνεργάζεται με Combines with	ΤΗΝ ΤΑΠΑ P.8077

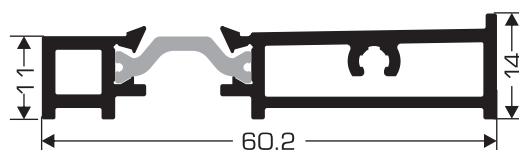

ΣΕ ΟΛΑ ΤΑ ΧΡΩΜΑΤΑ
ΠΛΗΝ ΤΟΥ ΛΕΥΚΟΥ
ΔΙΑΤΙΘΕΤΑΙ ΚΑΙ ΣΕ ΜΗΚΟΣ 1,2m
THE ITEM CAN ALSO BE
SUPPLIED IN 1,2m WIDTH IN ALL
COLORATIONS APART WHITE

ΜΗΚΟΣ / LENGTH 6m
TEM/ΔΕΜΑ PCS/BUNDLE 5

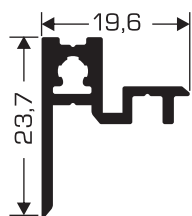

EL 8070	ΠΡΟΣΘΕΤΟ ΦΥΛΛΟΥ ΓΙΑ ΧΡΗΣΗ ΑΝΕΜΟΦΡΑΚΤΗ SHASH'S ADDITIONAL PROFILE FOR USE OF WINDSHIELD
Βάρος - Weight 276 (gr/m)	Περίμετρος - Perimeter 105 mm
Συνεργάζεται με Combines with	P.807 1

ΜΗΚΟΣ / LENGTH 6,5m
TEM/ΔΕΜΑ PCS/BUNDLE 10

ΣΕ ΟΛΑ ΤΑ ΧΡΩΜΑΤΑ
ΠΛΗΝ ΤΟΥ ΛΕΥΚΟΥ
ΔΙΑΤΙΘΕΤΑΙ ΚΑΙ ΣΕ ΜΗΚΟΣ 1,2m
THE ITEM CAN ALSO BE
SUPPLIED IN 1,2m WIDTH IN ALL
COLORATIONS APART WHITE

EL 8071	ΠΡΟΣΘΕΤΟ ΦΥΛΛΟΥ ΓΙΑ ΧΡΗΣΗ ΚΑΤΩΚΑΣΙ SHASH'S ADDITIONAL PROFILE FOR USE OF THRESHOLD
Βάρος - Weight 276 (gr/m)	Περίμετρος - Perimeter 86 mm
Συνεργάζεται με Combines with	P.807 1

ΜΗΚΟΣ / LENGTH 6m
TEM/ΔΕΜΑ PCS/BUNDLE 10

ΣΕ ΟΛΑ ΤΑ ΧΡΩΜΑΤΑ
ΠΛΗΝ ΤΟΥ ΛΕΥΚΟΥ
ΔΙΑΤΙΘΕΤΑΙ ΚΑΙ ΣΕ ΜΗΚΟΣ 1,2m
THE ITEM CAN ALSO BE
SUPPLIED IN 1,2m WIDTH IN ALL
COLORATIONS APART WHITE

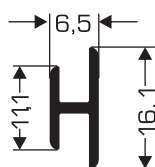

EL 8034	ΕΝΩΤΙΚΟ ΠΡΟΦΙΛ ΓΙΑ ΚΑΣΕΣ JOINING PROFILE FOR FRAMES
Βάρος - Weight 108 (gr/m)	Περίμετρος - Perimeter 62 mm

ΜΗΚΟΣ / LENGTH 6,5m
TEM/ΔΕΜΑ PCS/BUNDLE 10

EL 6772	ΑΡΜΟΚΑΛΥΠΤΡΟ OUTER COVER
Βάρος - Weight 284 (gr/m)	Περίμετρος - Perimeter 172 mm
Γωνία Επιπεδότητας Alignment Corner	GE. 1202.INOX

ΜΗΚΟΣ / LENGTH 6m
TEM/ΔΕΜΑ PCS/BUNDLE 10

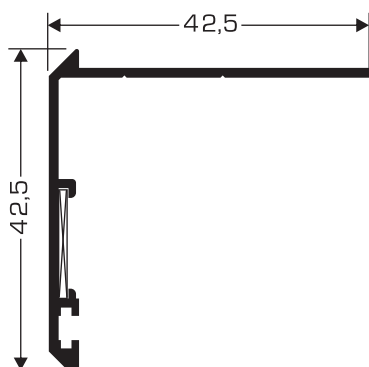
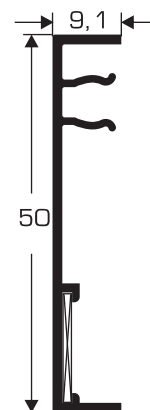

EL 2080	ΑΡΜΟΚΑΛΥΠΤΡΟ OUTER COVER
Βάρος - Weight 338 (gr/m)	Περίμετρος - Perimeter 191 mm
Γωνία Επιπεδότητας Alignment Corner	GE. 1202.INOX

ΜΗΚΟΣ / LENGTH 6m
TEM/ΔΕΜΑ PCS/BUNDLE 10

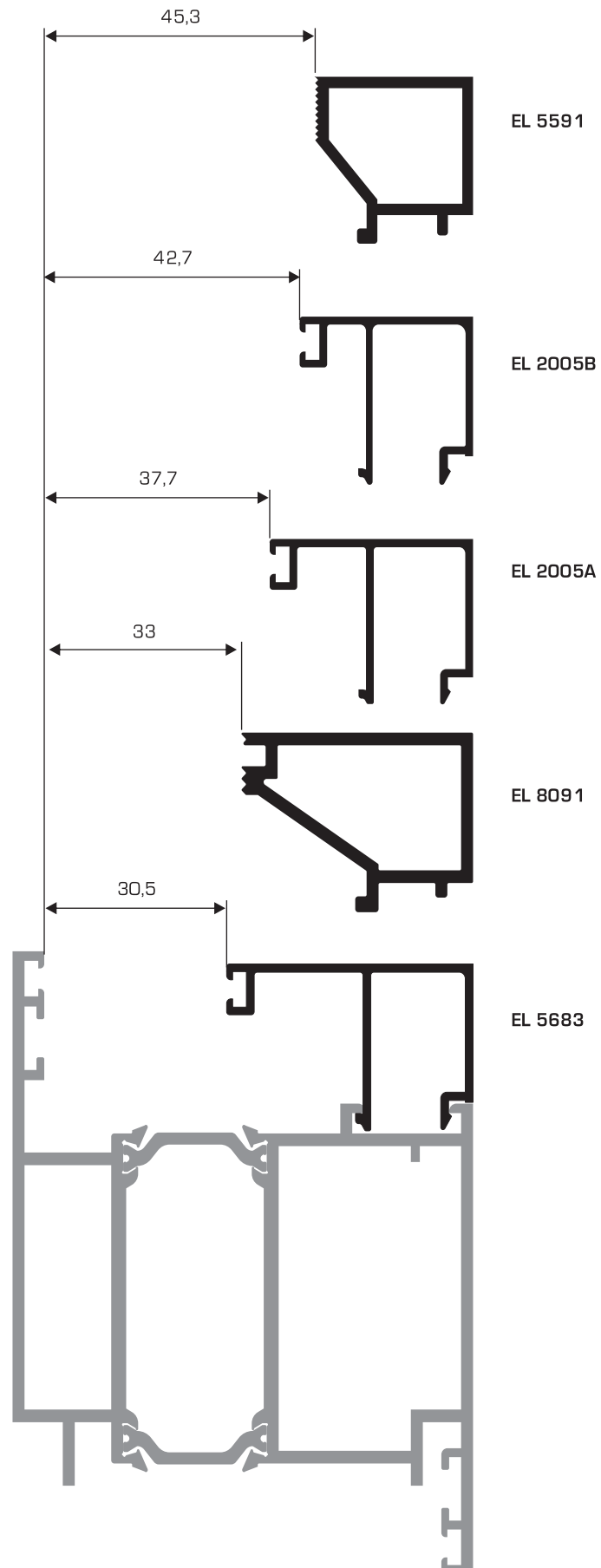

The first part of the document discusses the importance of maintaining accurate records of all transactions. It emphasizes that every entry, no matter how small, should be recorded to ensure the integrity of the financial data. This includes not only sales and purchases but also expenses and income. The document provides a detailed list of items that should be tracked, such as inventory levels, customer orders, and supplier invoices. It also outlines the procedures for recording these transactions, including the use of specific forms and the assignment of responsibilities to different staff members. The second part of the document focuses on the analysis of the recorded data. It describes various methods for identifying trends, such as comparing monthly sales figures and analyzing the impact of seasonal fluctuations. The document also discusses the importance of regular audits to verify the accuracy of the records and to detect any potential discrepancies. Finally, the document concludes with a summary of the key findings and recommendations for improving the record-keeping process. It suggests implementing more robust software solutions and providing additional training for staff to ensure that all transactions are recorded accurately and consistently.

EL - 8000



■	Συνοπτικά προφίλ - Synoptic profiles
■	Προφίλ - Profiles
■	Τομές - Sections
■	Κοπές - Cuttings
■	Εξαρτήματα - Accessories
■	Κατεργασίες - Constructions' Specifications
■	3d's

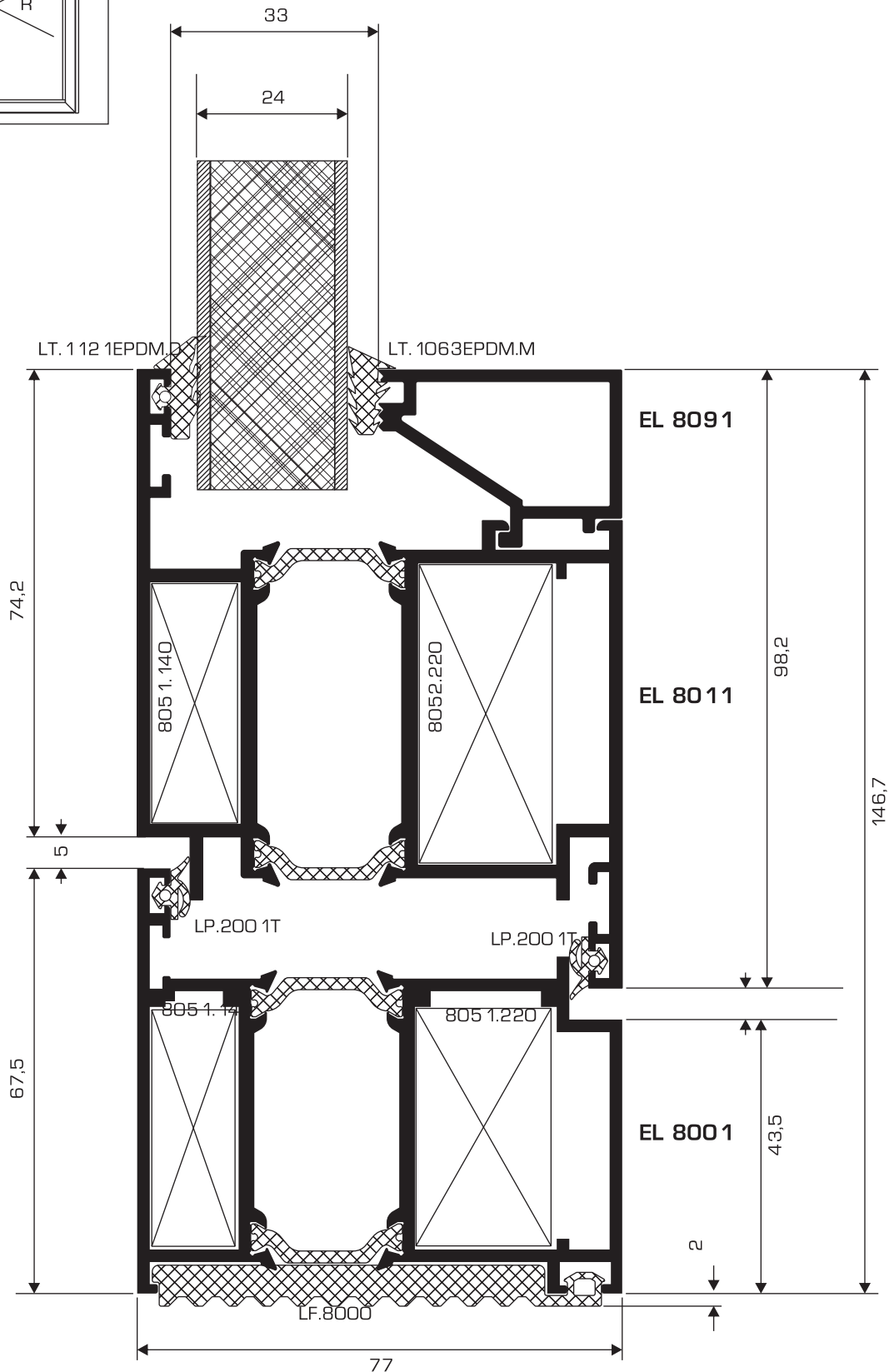
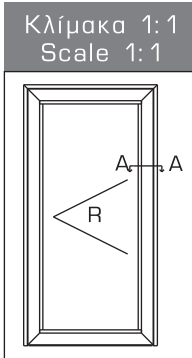

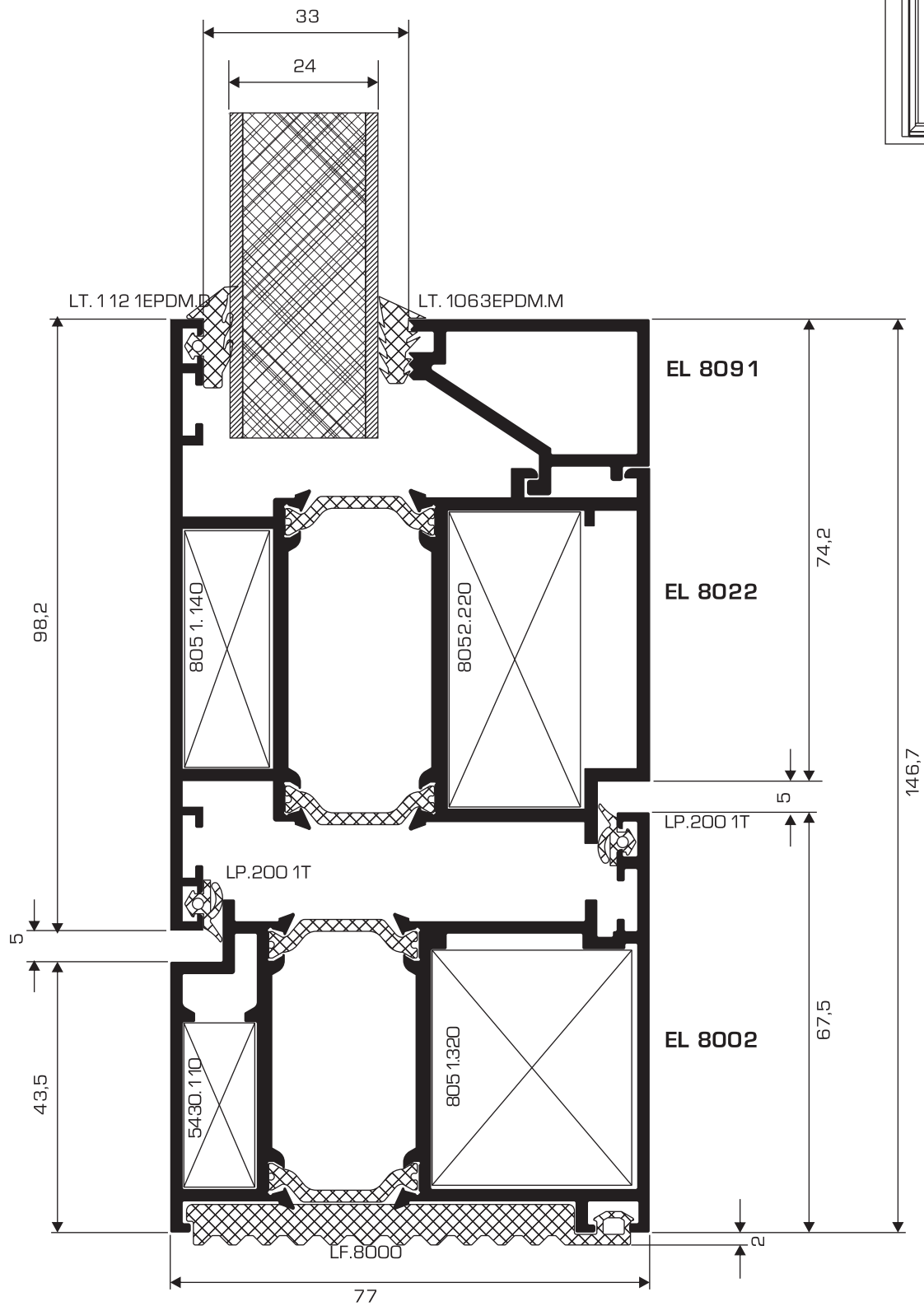
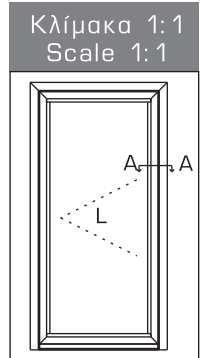

Κλίμακα 1:1
Scale 1:1

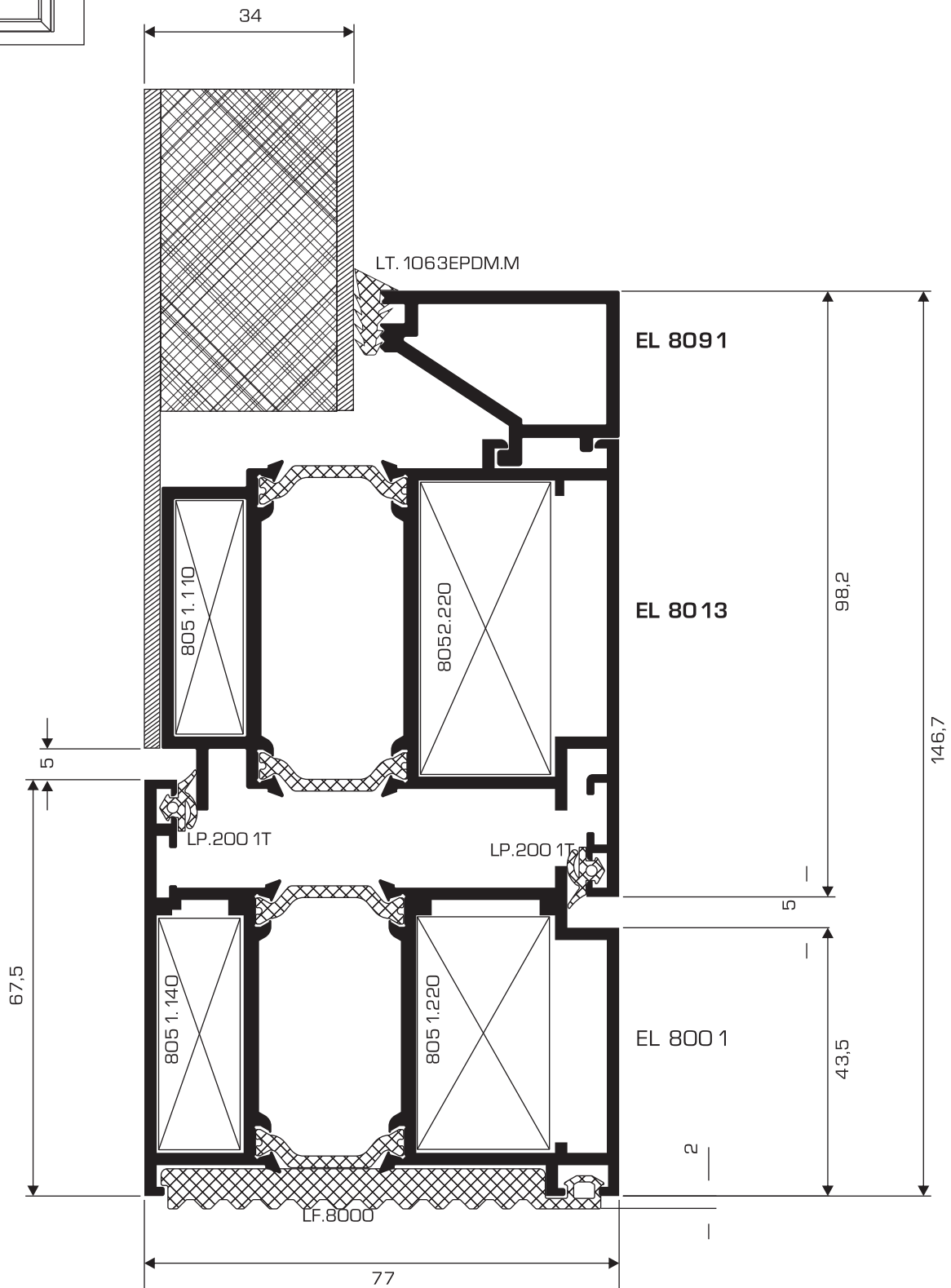
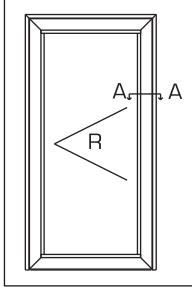

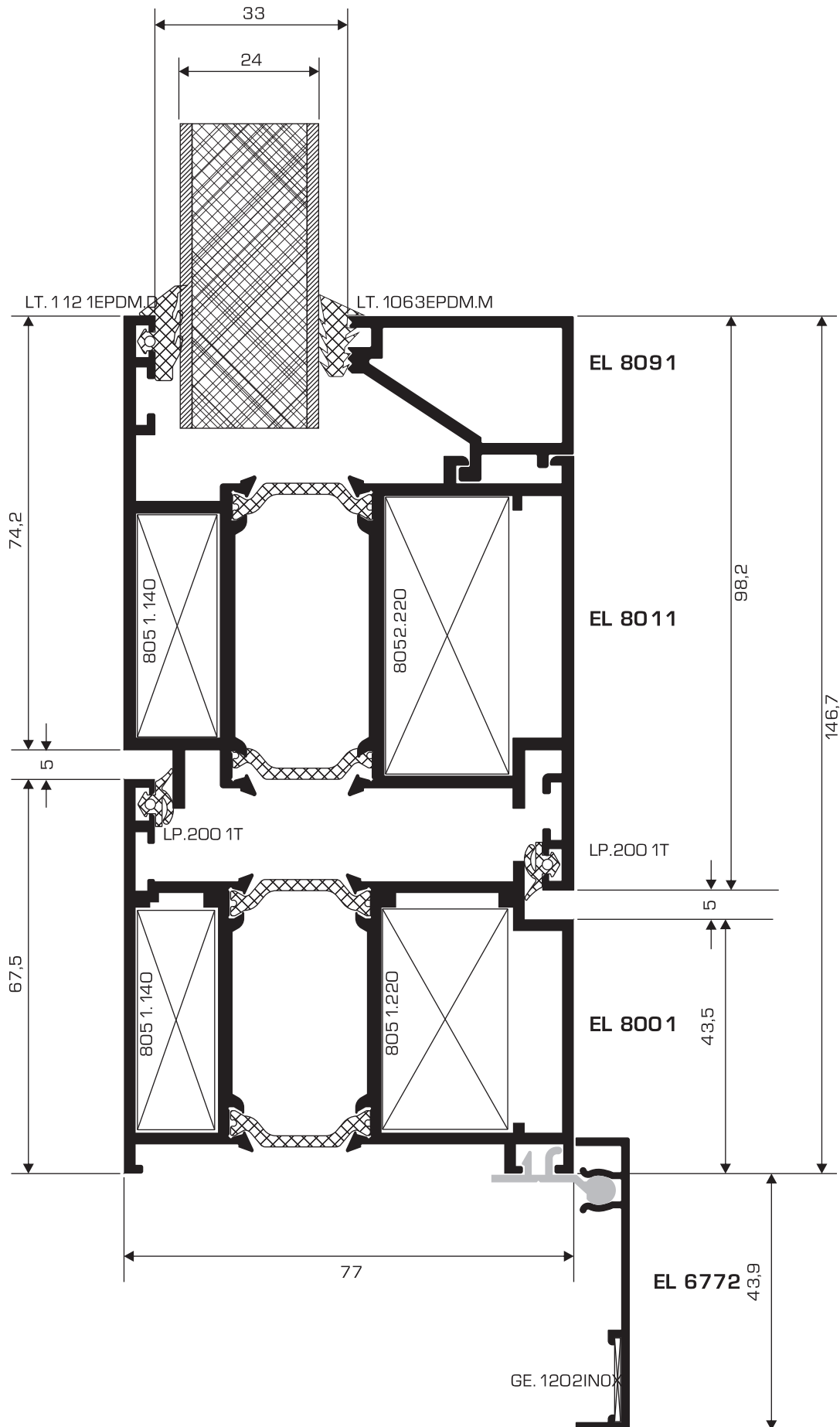
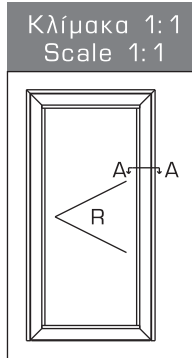

Κλίμακα 1:1
Scale 1:1

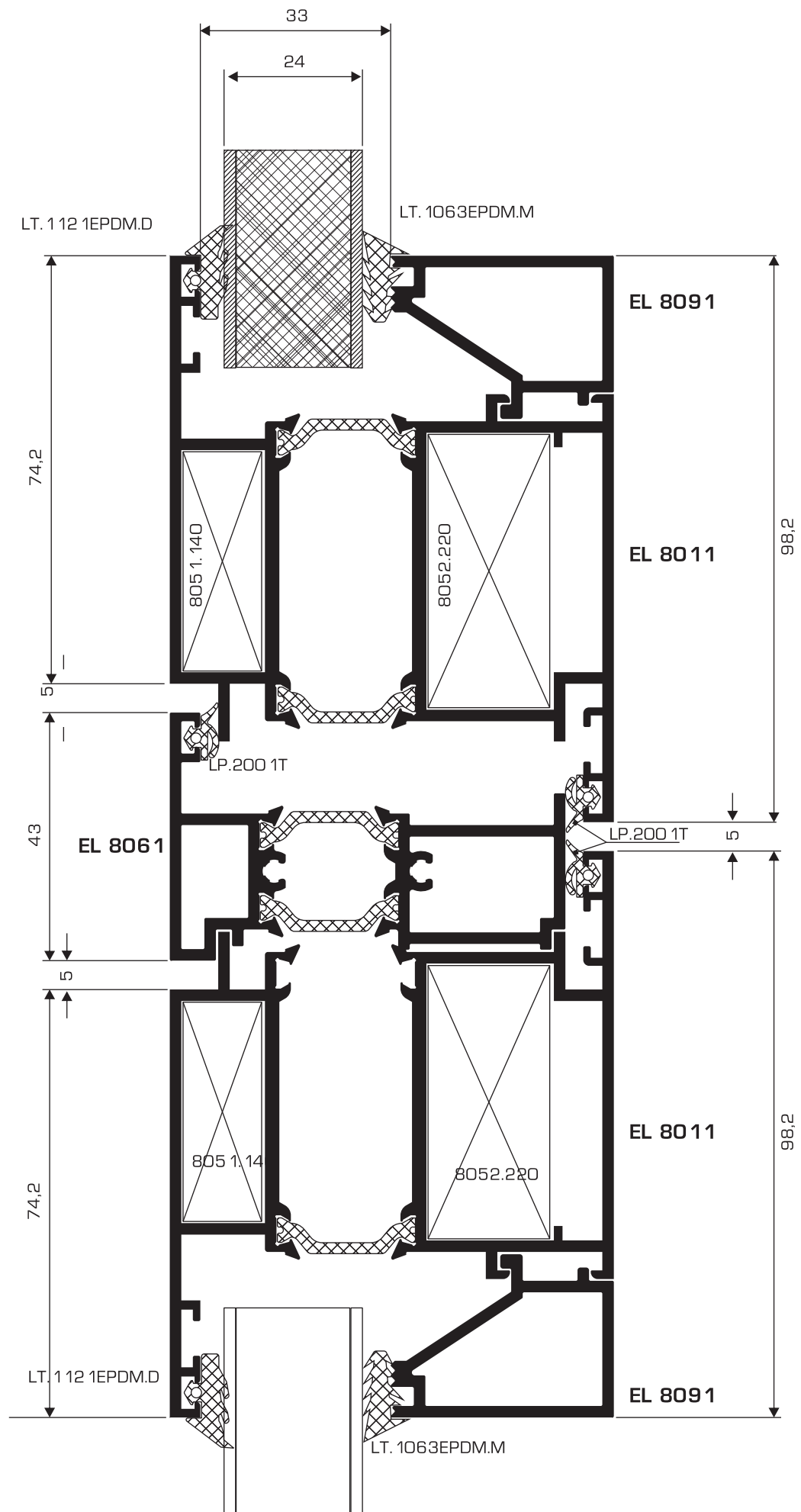
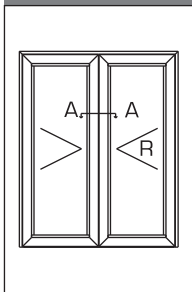

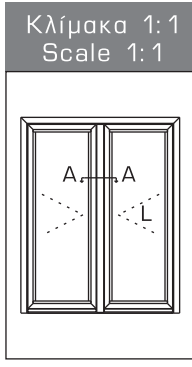
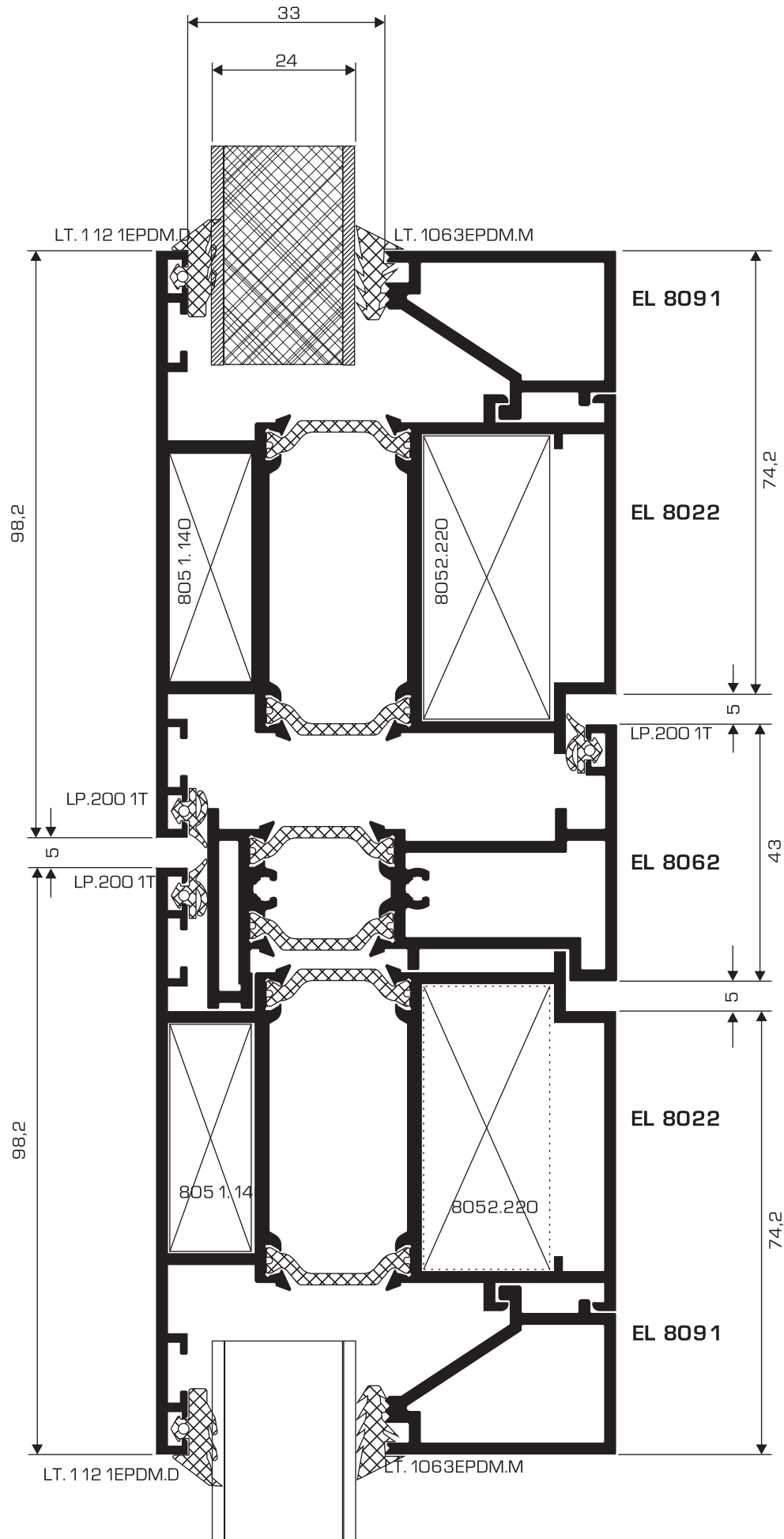

Κλίμακα 1:1
Scale 1:1

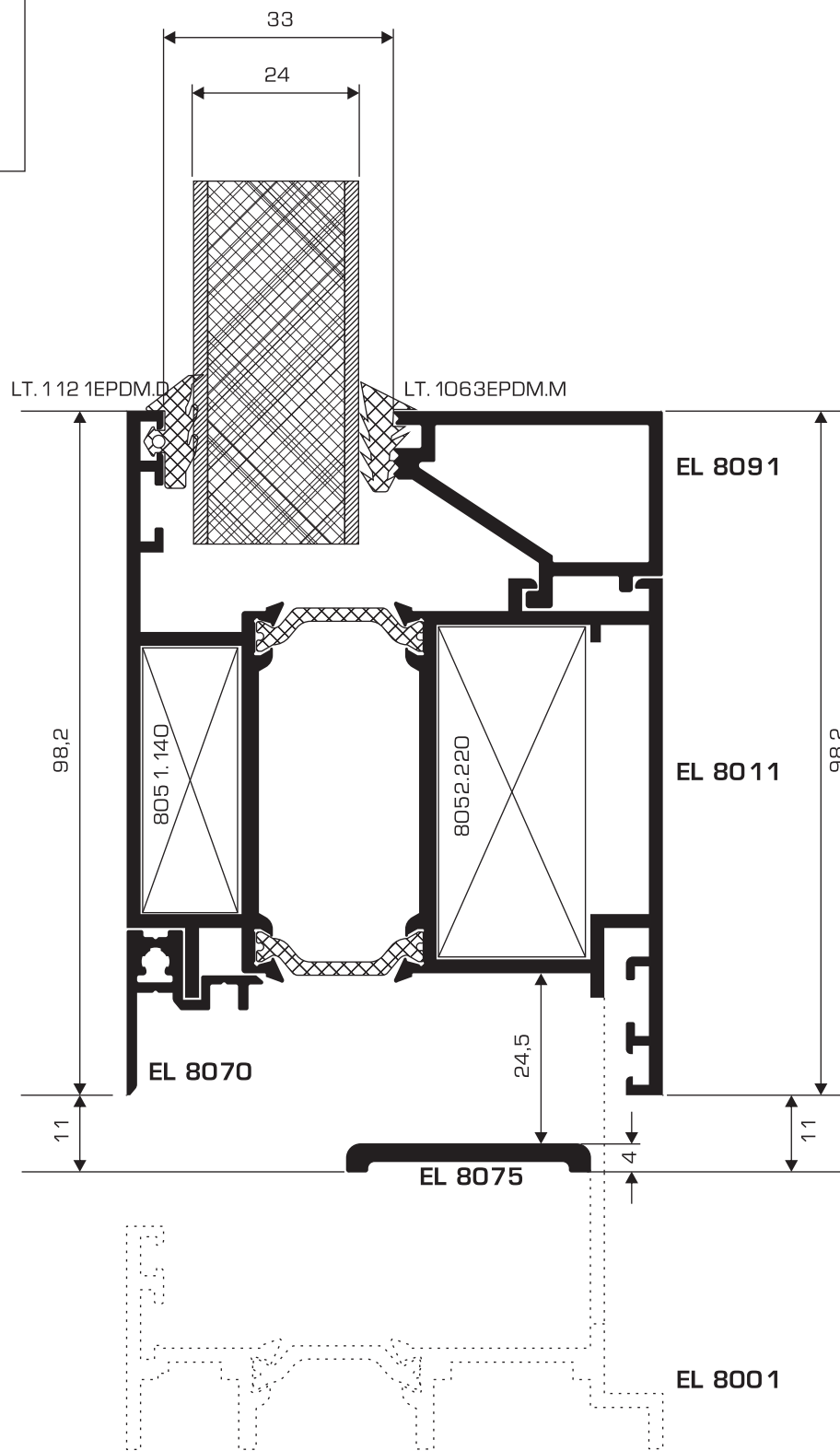
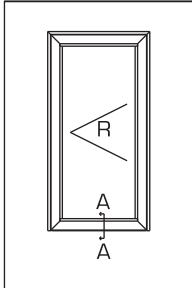

Κλίμακα 1:1
 Scale 1:1

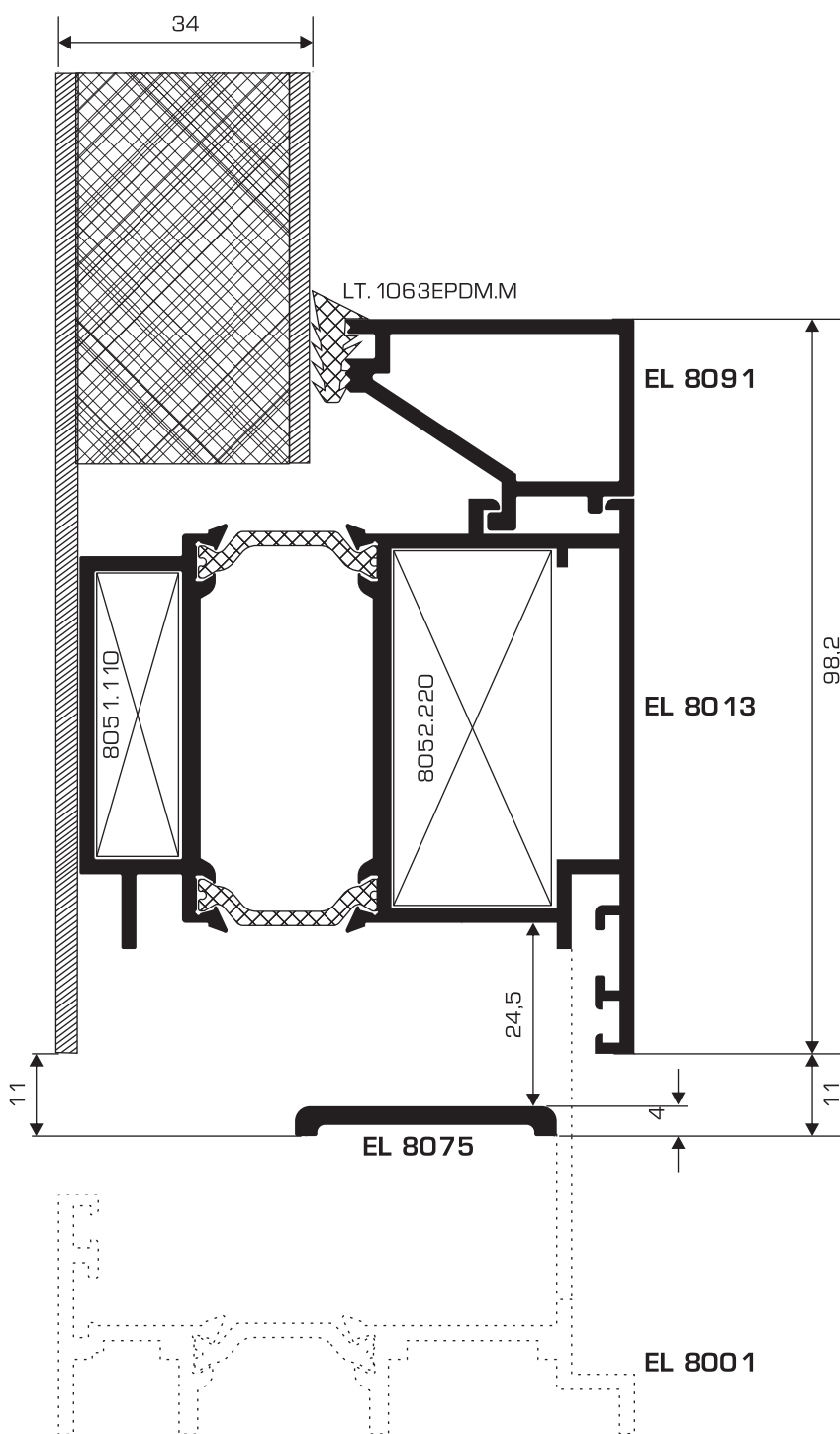
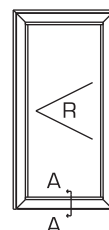

Κλίμακα 1:1
Scale 1:1

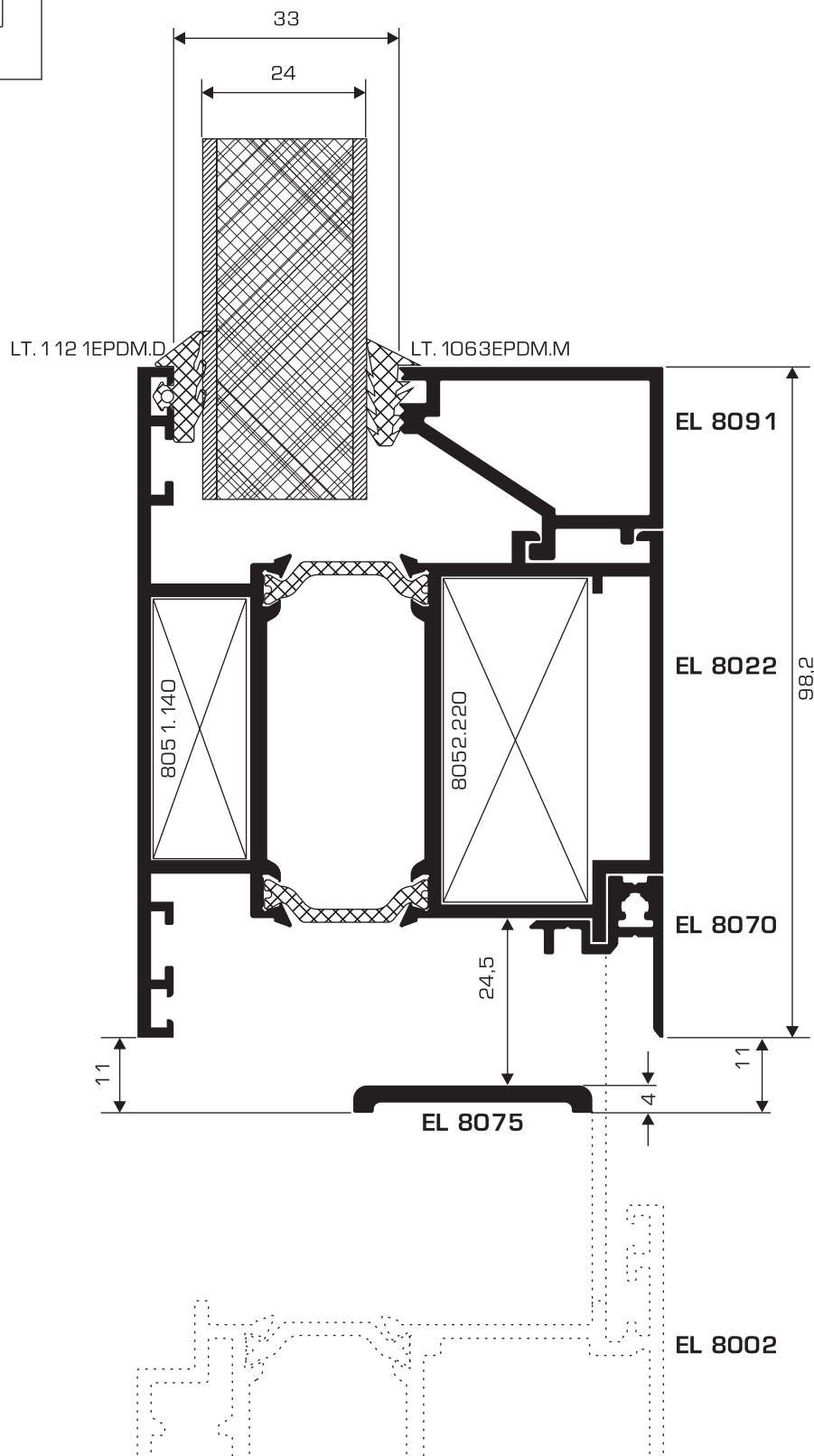
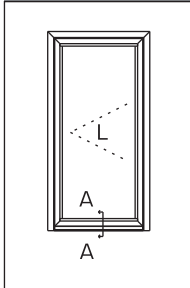

Κλίμακα 1:1
Scale 1:1

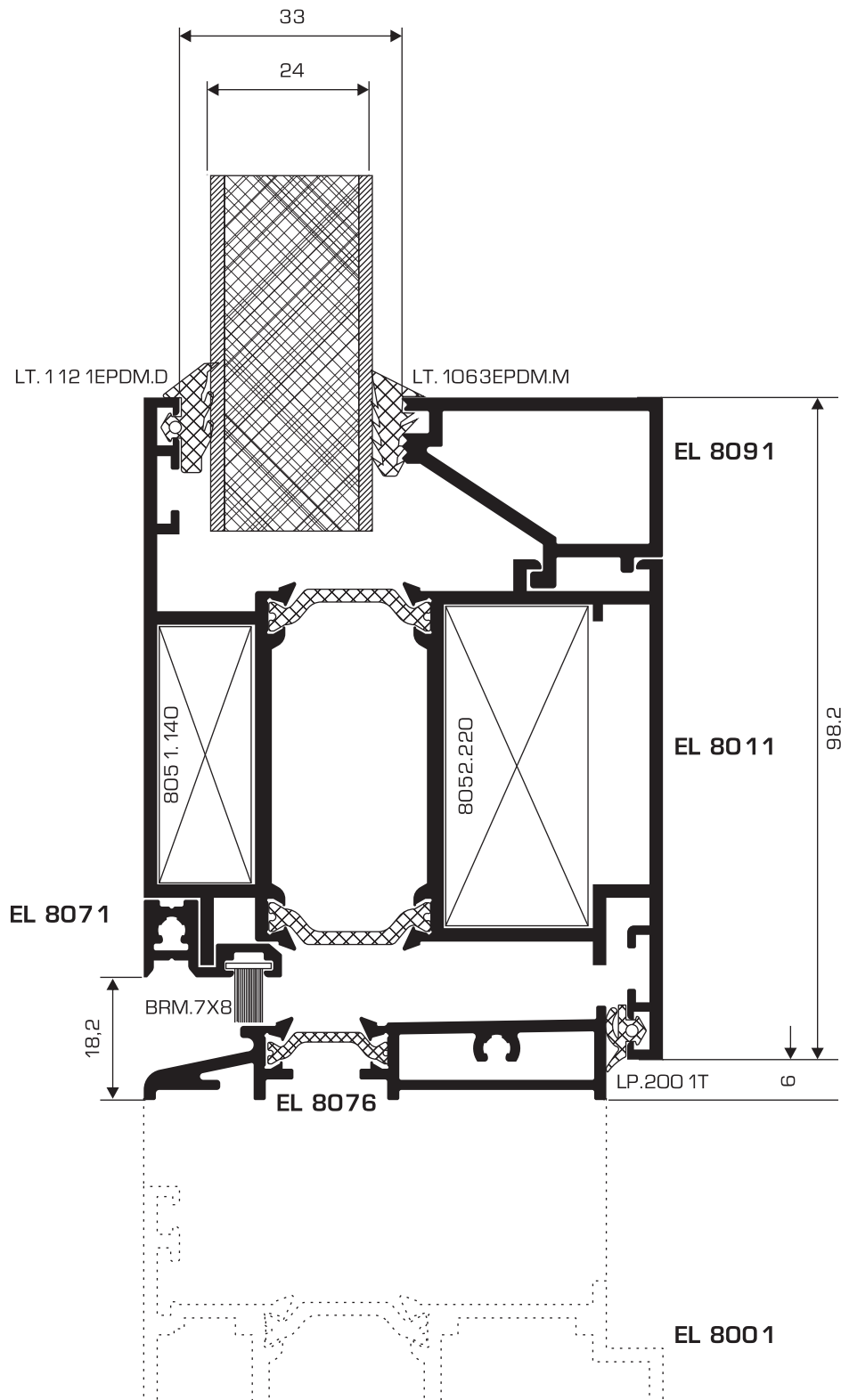

Κλίμακα 1:1
Scale 1:1

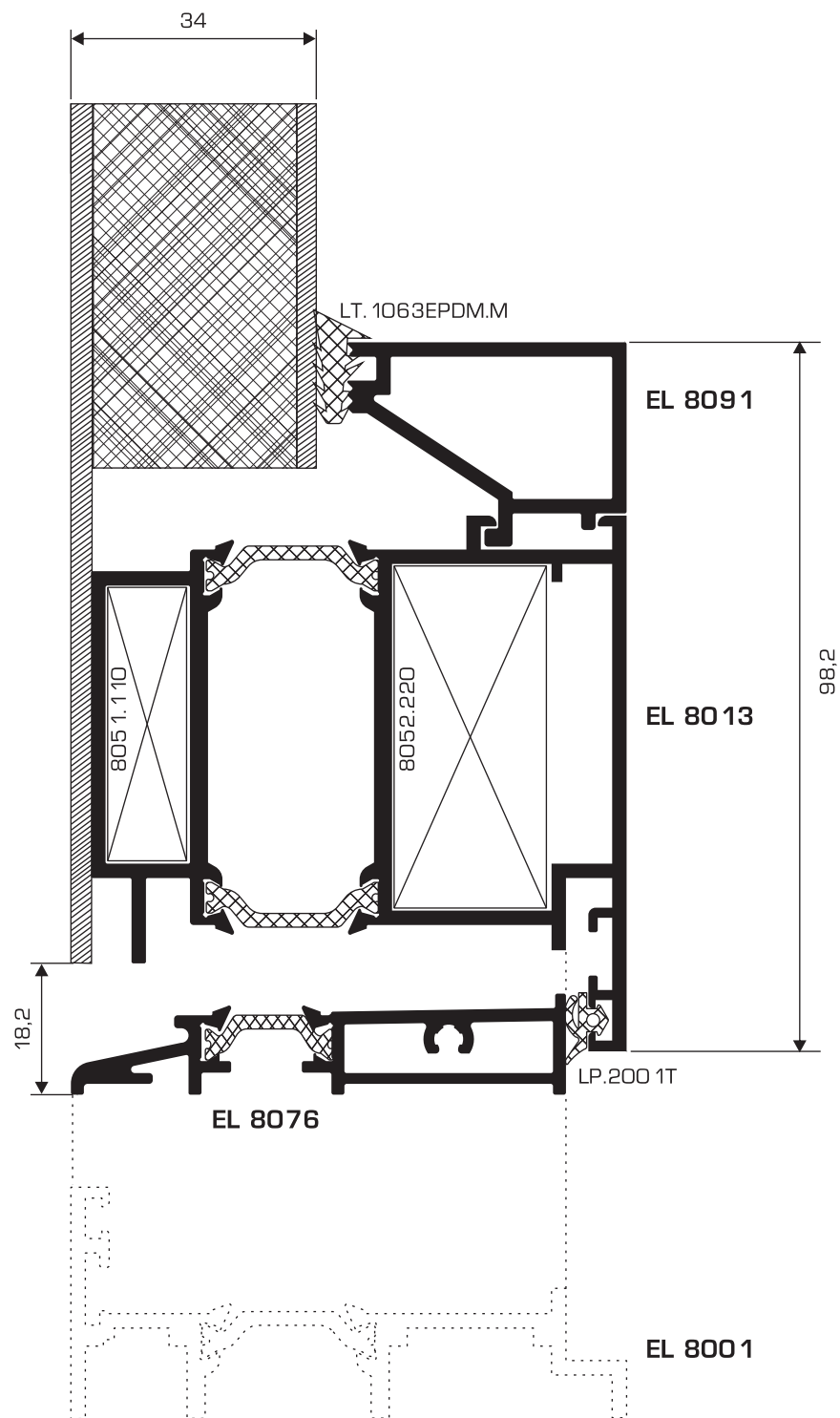
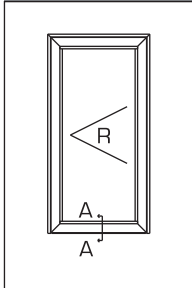

Κλίμακα 1:1
Scale 1:1

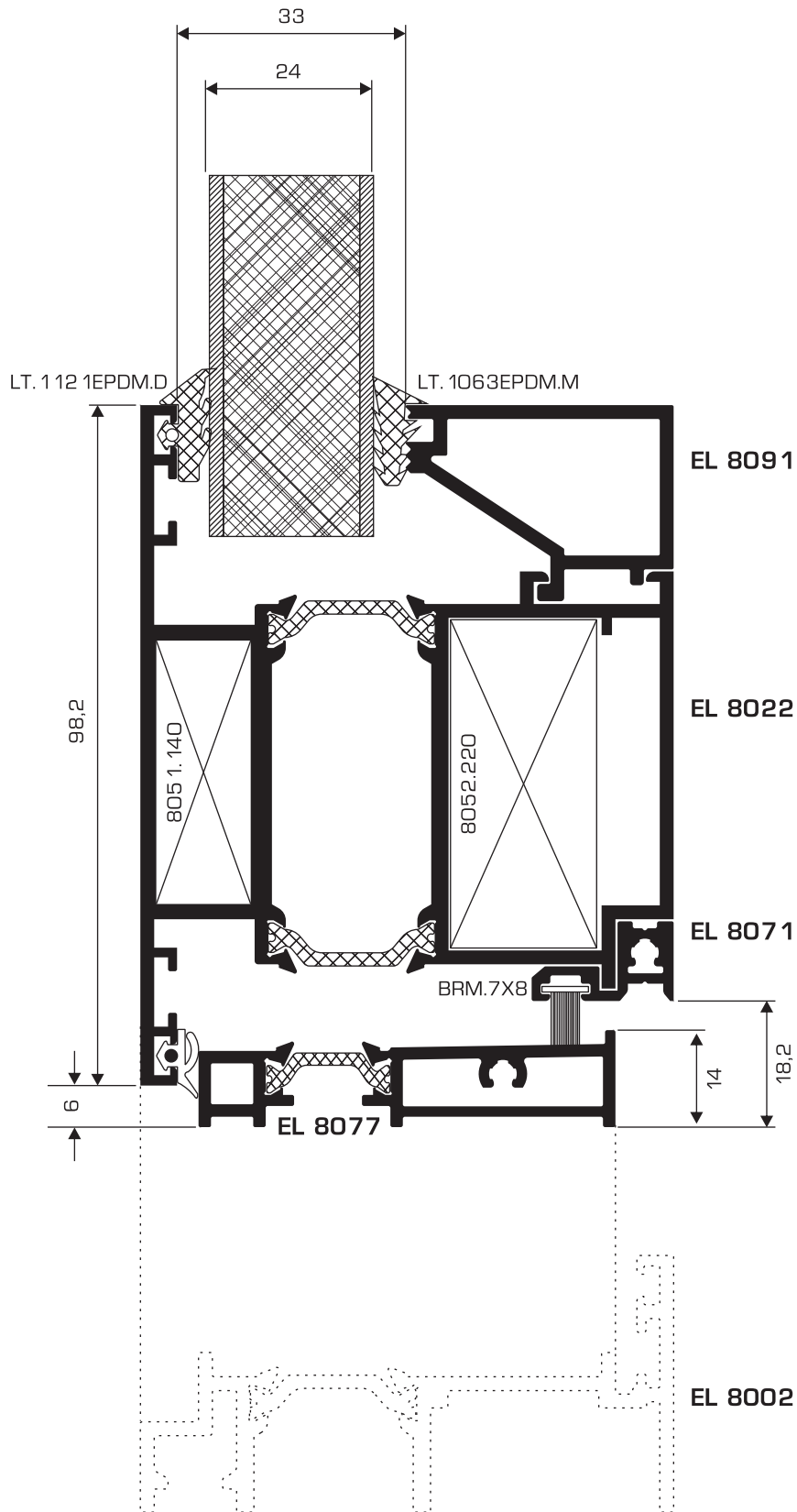
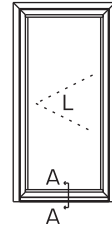

Κλίμακα 1:1
Scale 1:1

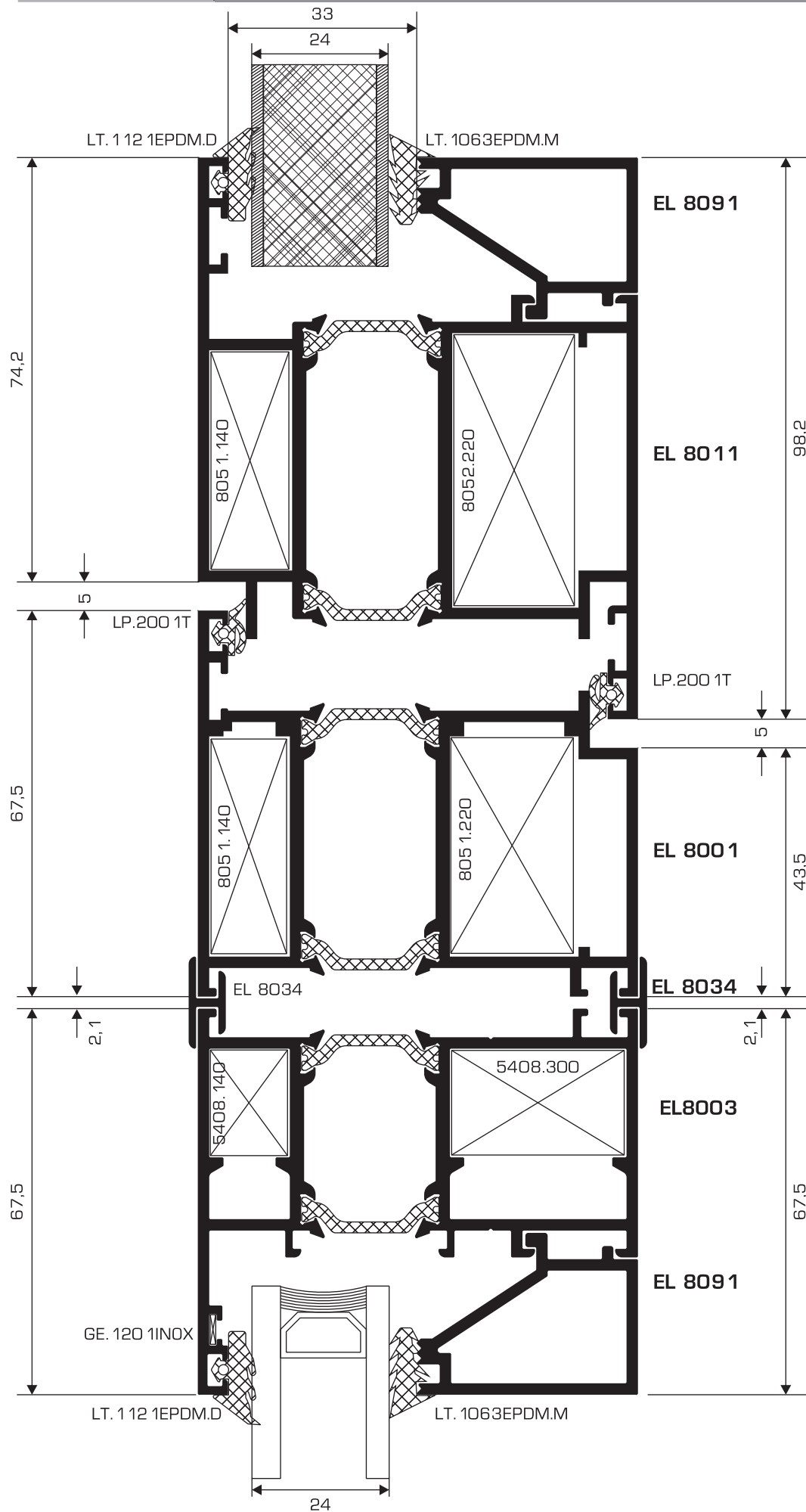
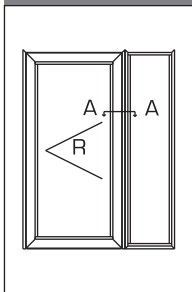

EL - 8000



■	Συνοπτικά προφίλ - Synoptic profiles
■	Προφίλ - Profiles
■	Τομές - Sections
■	Κοπές - Cuttings
■	Εξαρτήματα - Accessories
■	Κατεργασίες - Constructions' Specifications
■	3d's

Κοπές μονόφυλλης εισόδου ανοιγόμενης προς τα μέσα με χρήση ανεμοφράκτη
Cuttings for a single- sash entrance that opens inwards, with the use of windsield

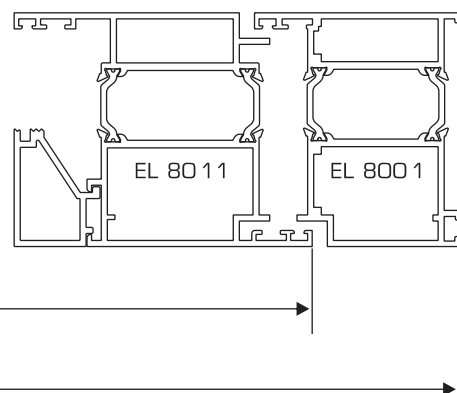
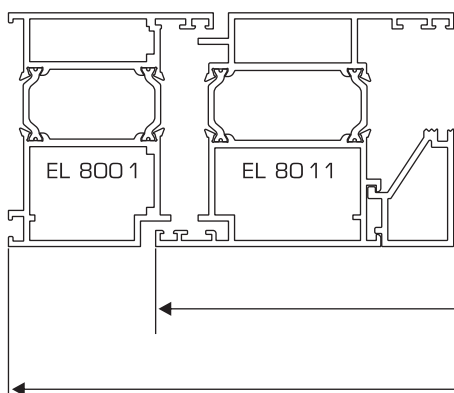
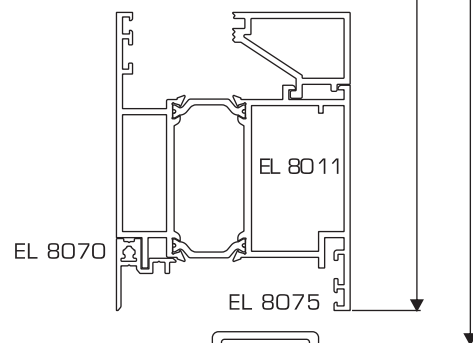
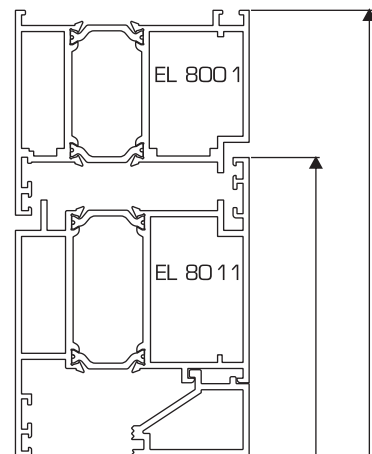
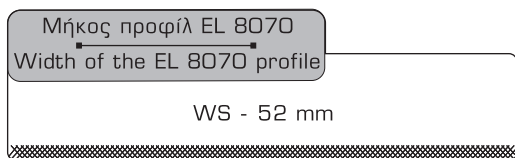
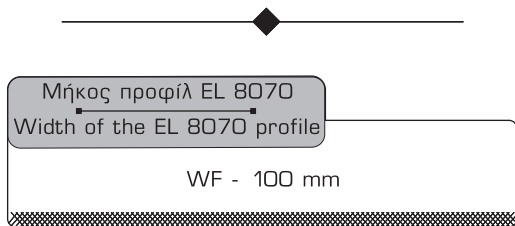
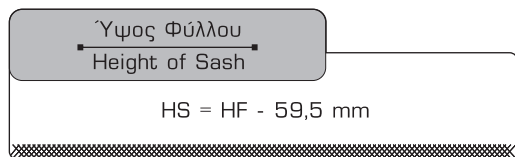
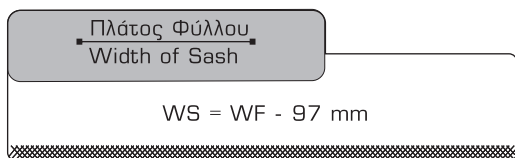

Κοπές μονόφυλλης εισόδου ανοιγόμενης
προς τα μέσα με χρήση κατωκασιού
Cuttings for a single- sash entrance
that opens inwards, with the use of threshold

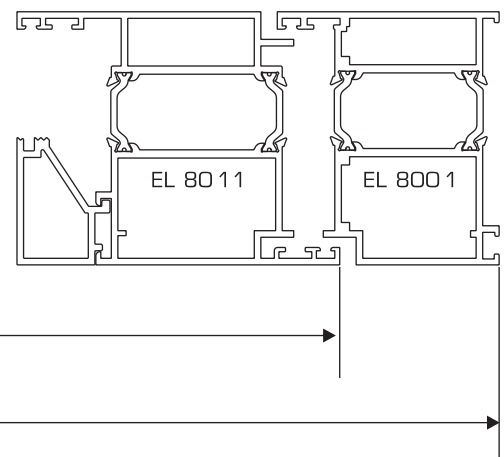
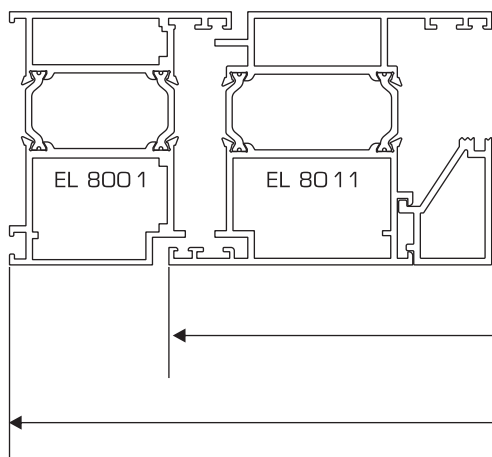
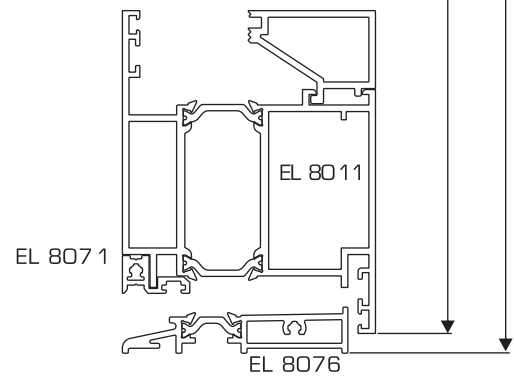
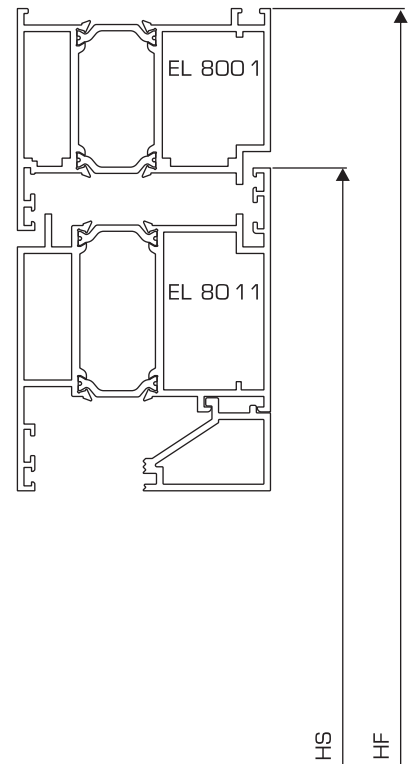
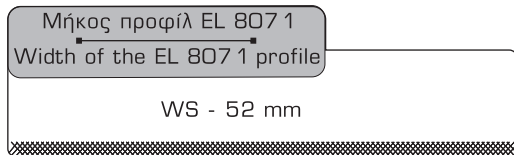
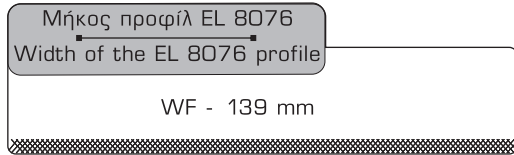
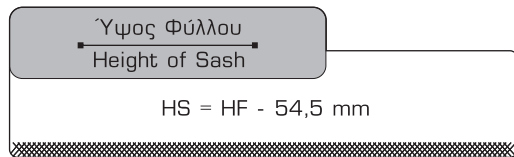
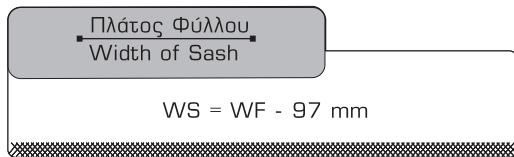

Κοπές μονόφυλλης εισόδου ανοιγόμενης προς τα έξω με χρήση ανεμοφράκτη
Cuttings for a single- sash entrance that opens outwards, with the use of windshield

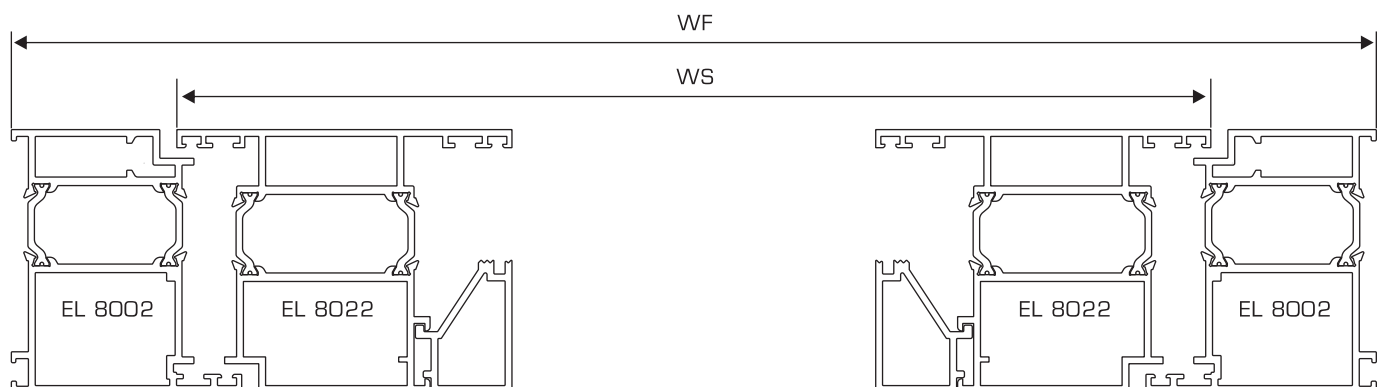
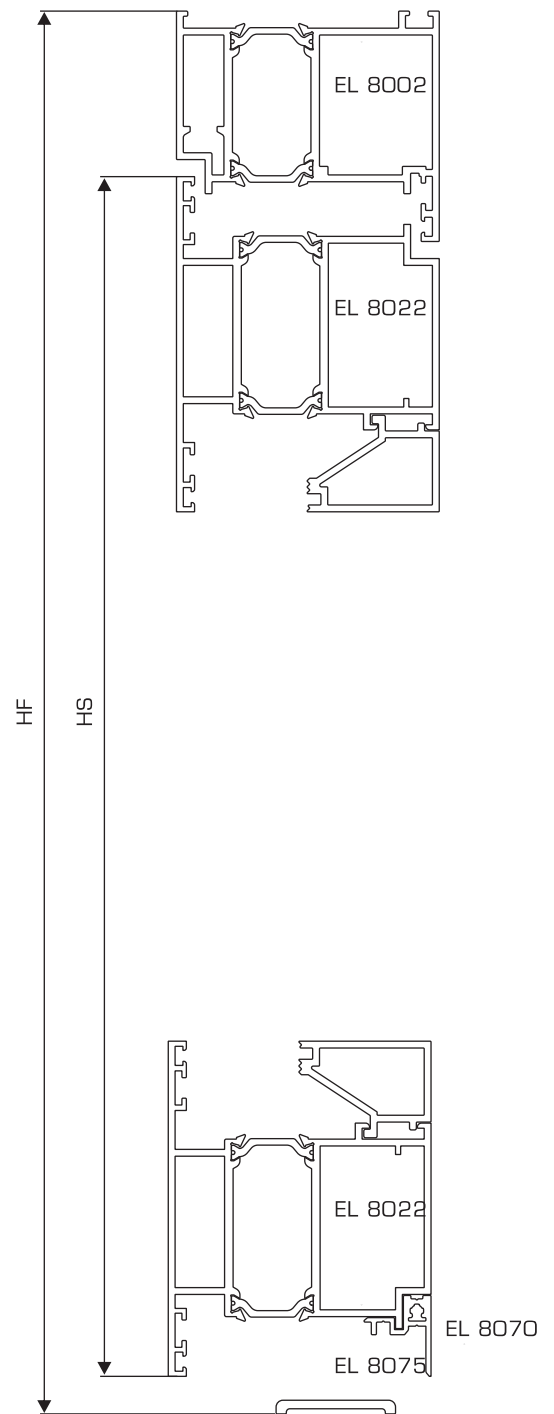
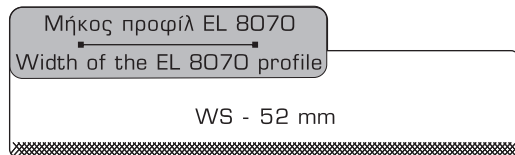
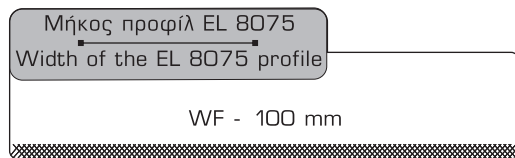
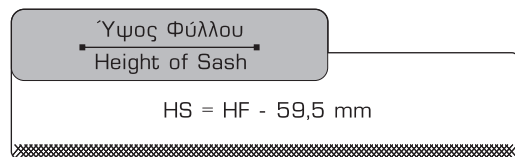
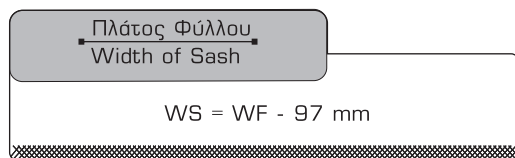

Κοπές μονόφυλλης εισόδου ανοιγόμενης προς τα έξω με χρήση κατωκασιού
Cuttings for a single- sash entrance that opens outwards, with the use of threshold

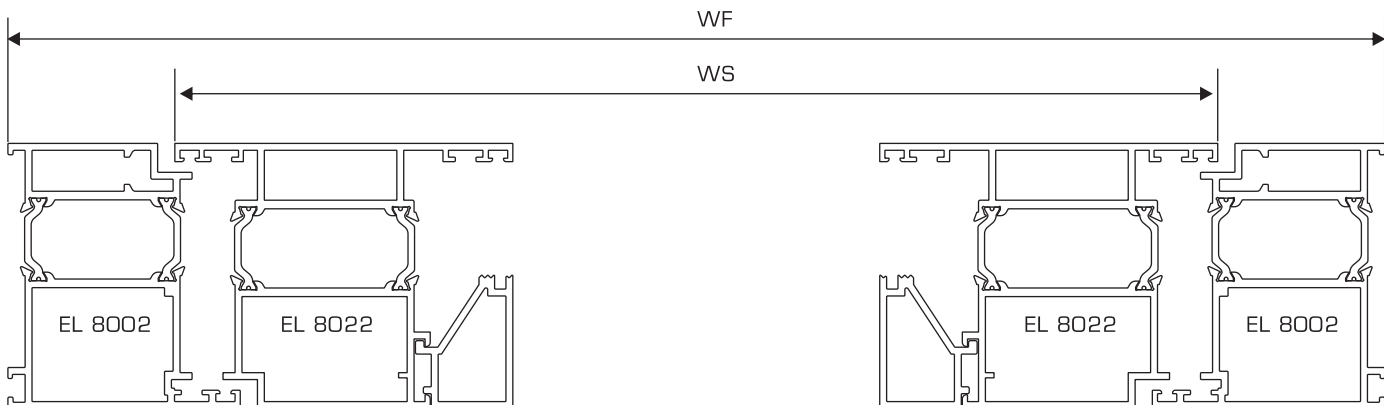
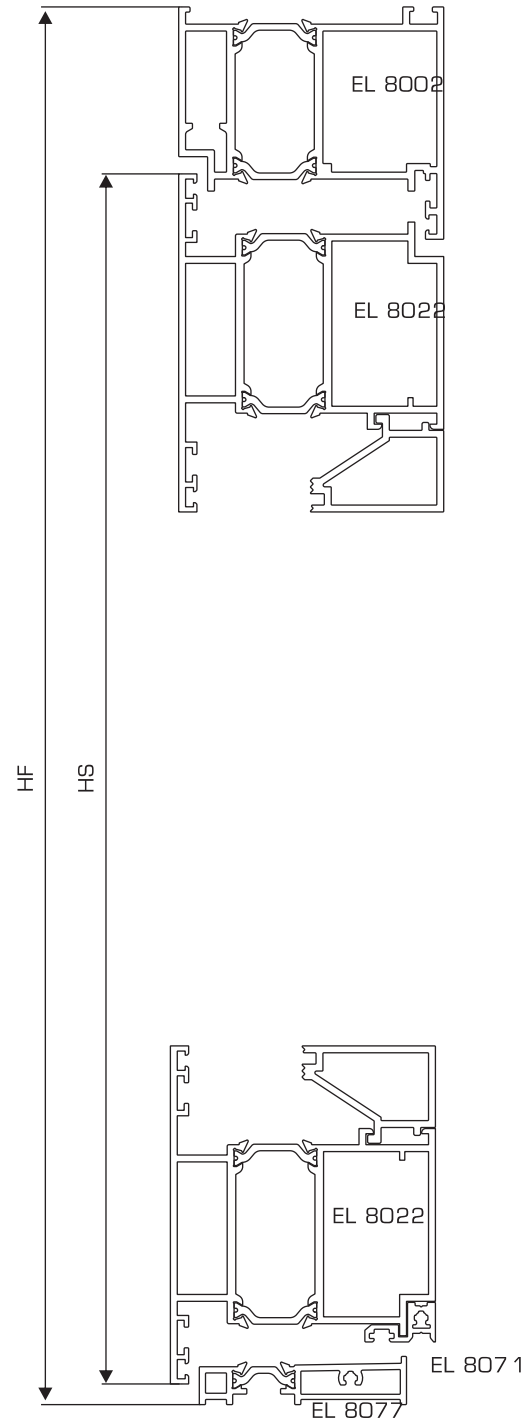
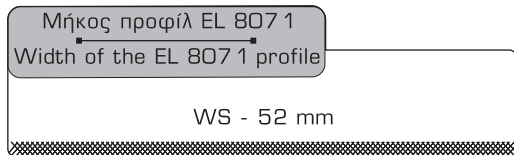
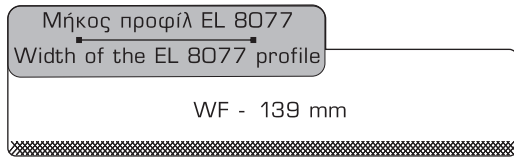
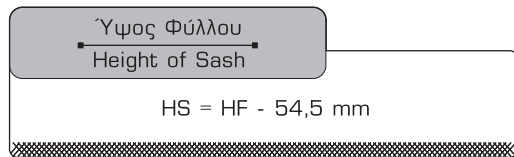
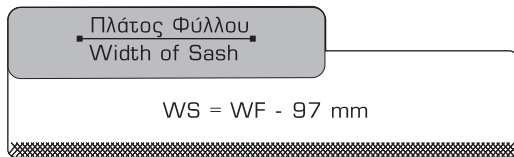

Κοπές δίφυλλης εισόδου ανοιγόμενης προς τα μέσα με χρήση ανεμοφράκτη

Cuttings for a double- sash entrance that opens inwards, with the use of windsield

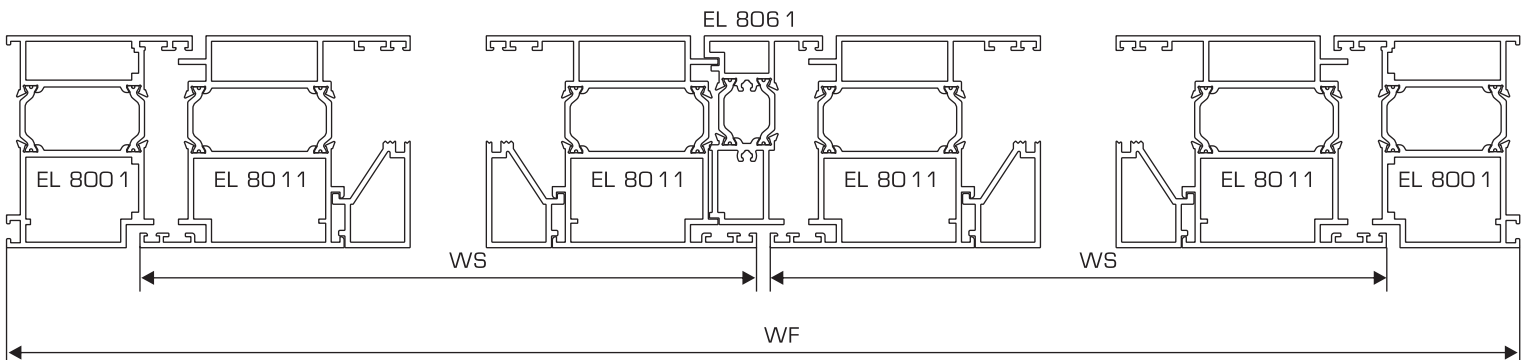
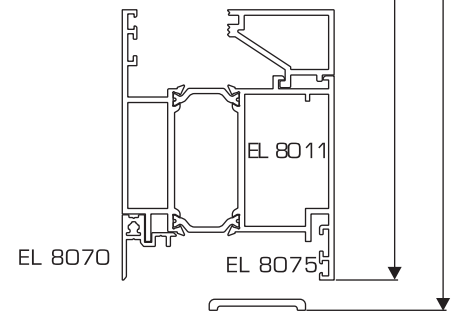
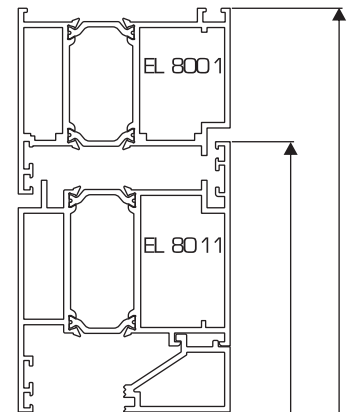
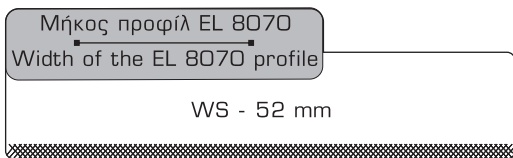
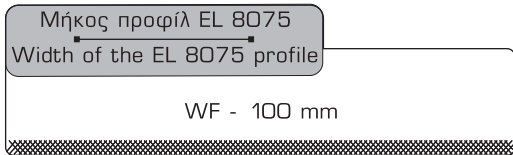
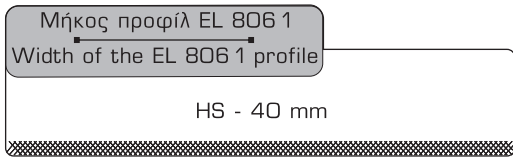
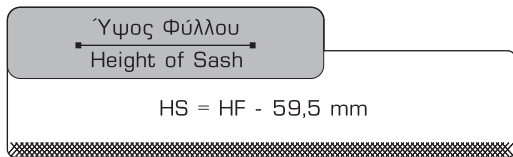
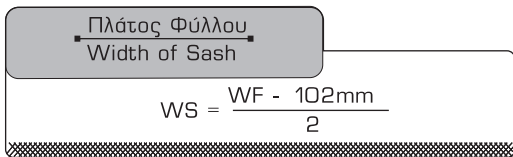

Κοπές δίφυλλης εισόδου ανοιγόμενης
προς τα μέσα με χρήση κατωκασιού

Cuttings for a double-sash entrance
that opens inwards, with the use of threshold

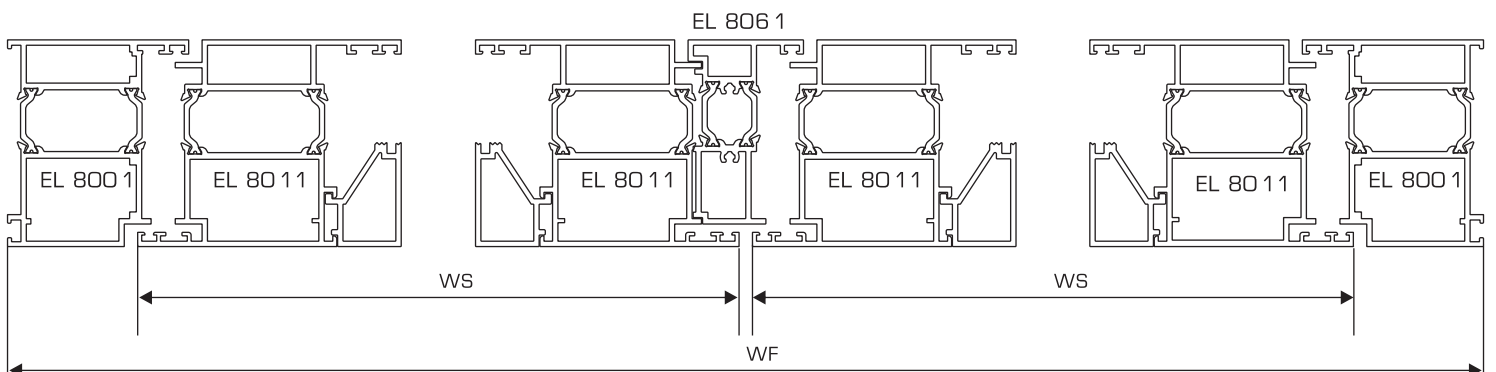
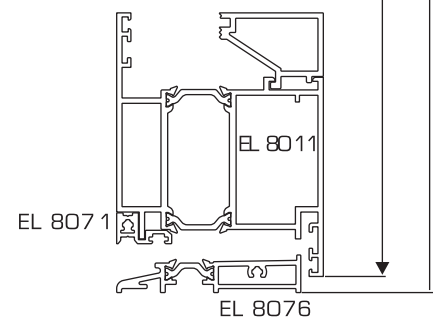
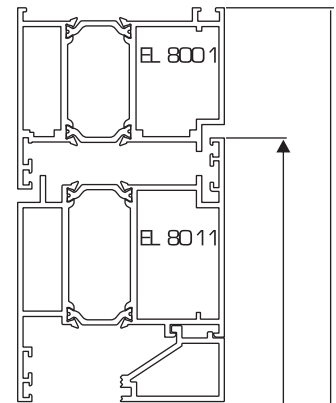
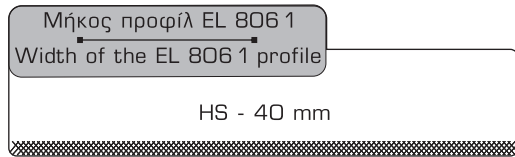
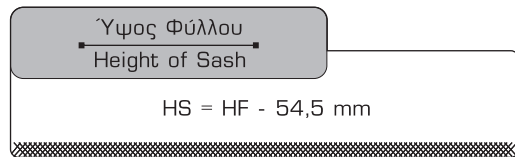
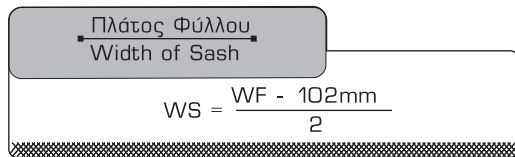

Κοπές δίφυλλης εισόδου ανοιγόμενης προς τα έξω με χρήση ανεμοφράκτη

Cuttings for a double- sash entrance that opens outwards, with the use of windshield

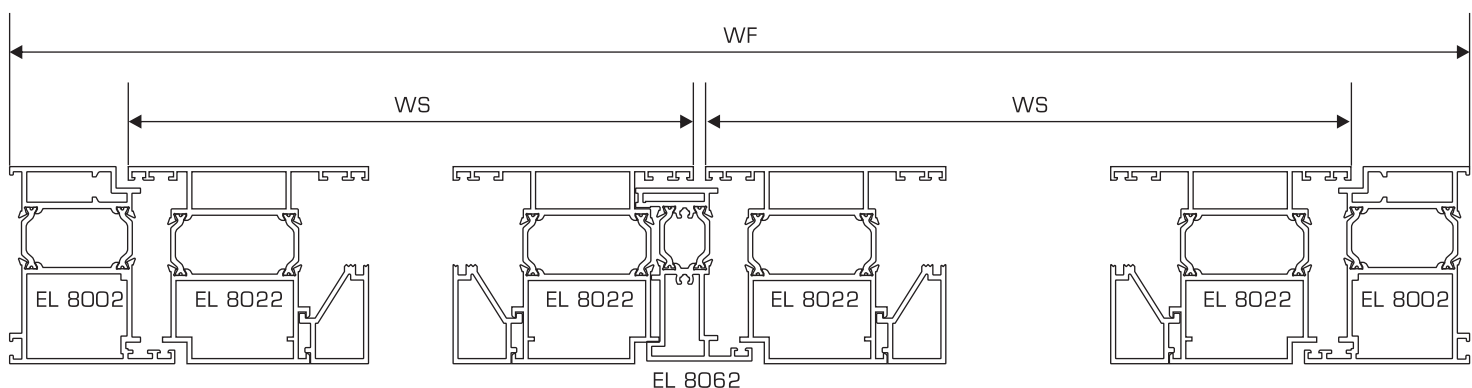
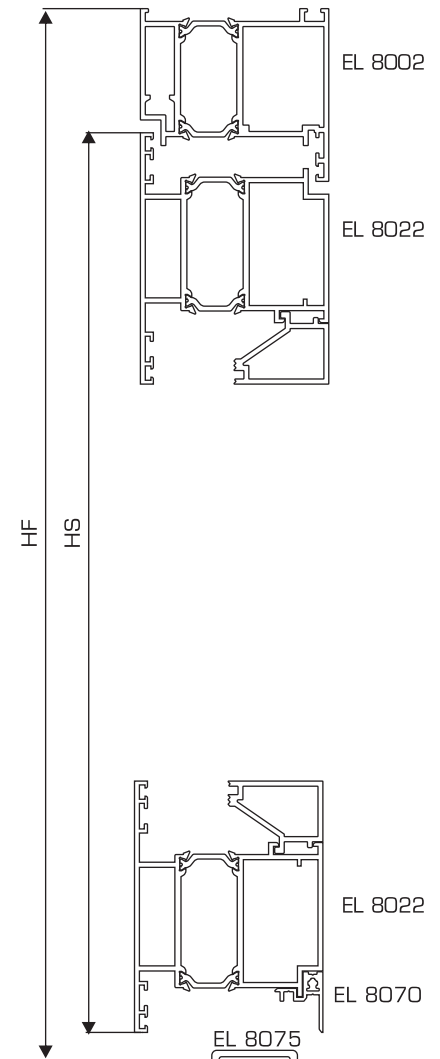
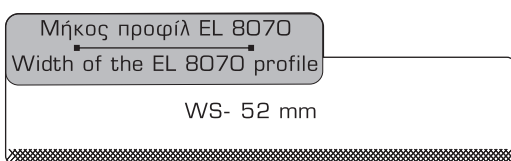
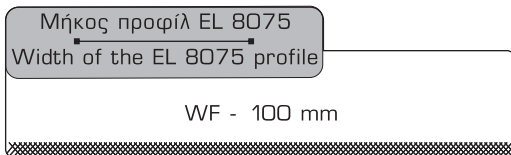
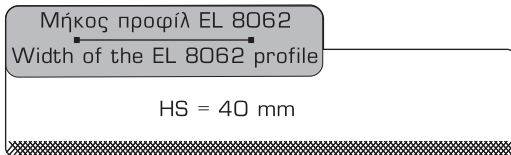
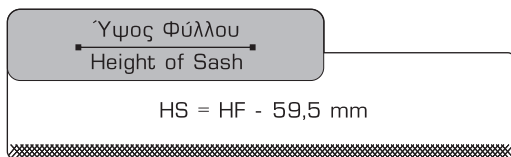
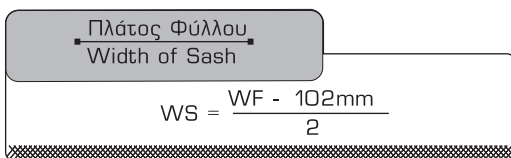

Κοπές δίφυλλης εισόδου ανοιγόμενης
προς τα έξω με χρήση κατωκασιού

Cuttings for a double- sash entrance
that opens outwards, with the use of threshold

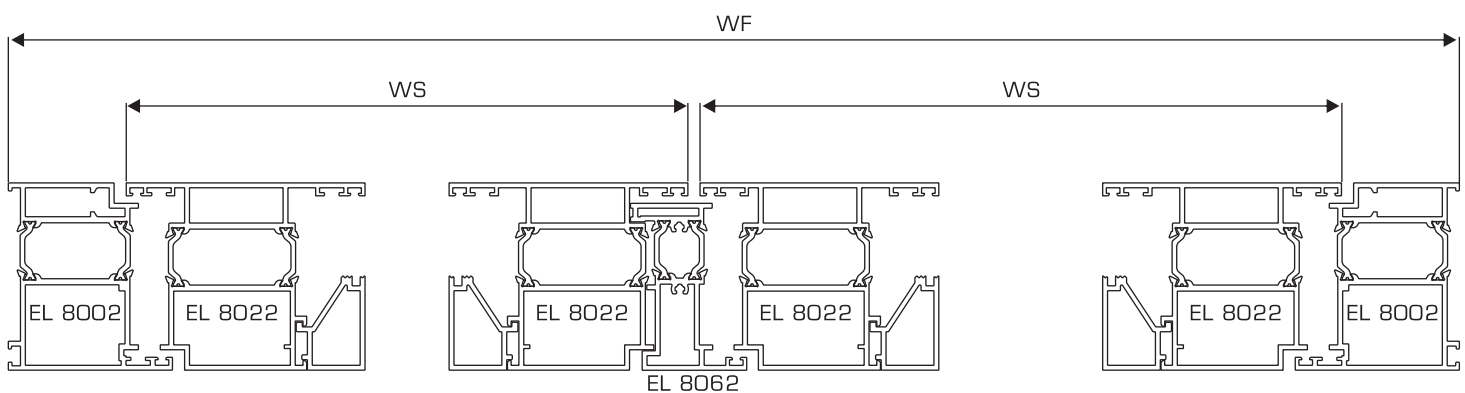
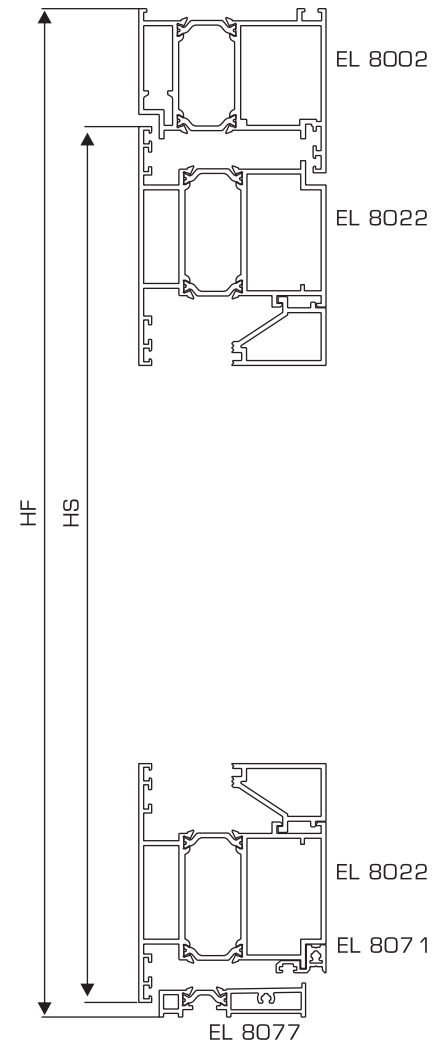
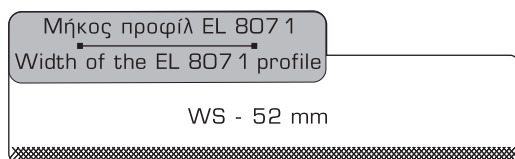
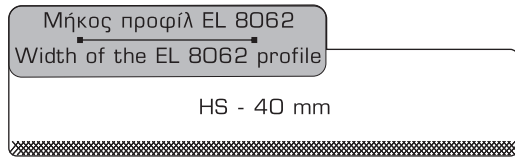
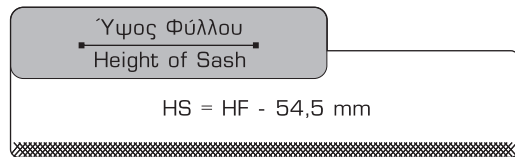
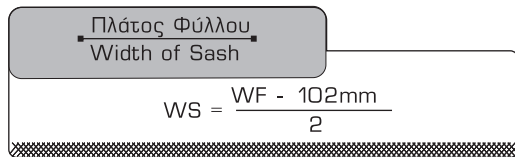

the 1990s, the number of people in the UK who are aged 65 and over has increased from 10.5 million to 13.5 million, and the number of people aged 75 and over has increased from 4.5 million to 6.5 million (Office for National Statistics 2000).

There is a growing awareness of the need to address the needs of older people, and the need to ensure that the health care system is able to meet the needs of older people. The Department of Health (2000) has published a strategy for older people, which sets out the government's commitment to improve the health and well-being of older people, and to ensure that the health care system is able to meet the needs of older people.

The strategy for older people is based on three main principles: (1) to improve the health and well-being of older people; (2) to ensure that the health care system is able to meet the needs of older people; and (3) to ensure that older people are able to live independently and actively in their own homes. The strategy sets out a range of measures to be taken to achieve these aims, including: (1) to improve the health and well-being of older people; (2) to ensure that the health care system is able to meet the needs of older people; and (3) to ensure that older people are able to live independently and actively in their own homes.

The strategy for older people is a key document in the development of health care for older people. It sets out the government's commitment to improve the health and well-being of older people, and to ensure that the health care system is able to meet the needs of older people. The strategy sets out a range of measures to be taken to achieve these aims, including: (1) to improve the health and well-being of older people; (2) to ensure that the health care system is able to meet the needs of older people; and (3) to ensure that older people are able to live independently and actively in their own homes.

The strategy for older people is a key document in the development of health care for older people. It sets out the government's commitment to improve the health and well-being of older people, and to ensure that the health care system is able to meet the needs of older people. The strategy sets out a range of measures to be taken to achieve these aims, including: (1) to improve the health and well-being of older people; (2) to ensure that the health care system is able to meet the needs of older people; and (3) to ensure that older people are able to live independently and actively in their own homes.

The strategy for older people is a key document in the development of health care for older people. It sets out the government's commitment to improve the health and well-being of older people, and to ensure that the health care system is able to meet the needs of older people. The strategy sets out a range of measures to be taken to achieve these aims, including: (1) to improve the health and well-being of older people; (2) to ensure that the health care system is able to meet the needs of older people; and (3) to ensure that older people are able to live independently and actively in their own homes.

The strategy for older people is a key document in the development of health care for older people. It sets out the government's commitment to improve the health and well-being of older people, and to ensure that the health care system is able to meet the needs of older people. The strategy sets out a range of measures to be taken to achieve these aims, including: (1) to improve the health and well-being of older people; (2) to ensure that the health care system is able to meet the needs of older people; and (3) to ensure that older people are able to live independently and actively in their own homes.

The strategy for older people is a key document in the development of health care for older people. It sets out the government's commitment to improve the health and well-being of older people, and to ensure that the health care system is able to meet the needs of older people. The strategy sets out a range of measures to be taken to achieve these aims, including: (1) to improve the health and well-being of older people; (2) to ensure that the health care system is able to meet the needs of older people; and (3) to ensure that older people are able to live independently and actively in their own homes.

The strategy for older people is a key document in the development of health care for older people. It sets out the government's commitment to improve the health and well-being of older people, and to ensure that the health care system is able to meet the needs of older people. The strategy sets out a range of measures to be taken to achieve these aims, including: (1) to improve the health and well-being of older people; (2) to ensure that the health care system is able to meet the needs of older people; and (3) to ensure that older people are able to live independently and actively in their own homes.

EL - 8000

■	Συνοπτικά Προφίλ - Synoptic Profiles
■	Προφίλ - Profiles
■	Τομές - Sections
■	Κοπές - Cuttings
■	Εξαρτήματα - Accessories
■	Κατεργασίες - Constructions' Specifications
■	3d's

Εξαρτήματα για όλους τους τύπους κατασκευών / Accessories for all constructions types

ΚΩΔ. CODE	ΜΟΡΦΗ SHAPE	ΠΕΡΙΓΡΑΦΗ DESCRIPTION	ΣΥΣΚ/ΣΙΑ PACKAGE	ΔΙΑΣΤ.ΣΥΣΚ PACK DIMENTIONS	ΧΡΩΜΑ COLOR	ΥΛΙΚΟ MATERIAL	ΣΥΝΕΡΓΑΖΕΤΑΙ ΜΕ COMBINES WITH
805 1.110		ΓΩΝΙΑ ΣΥΝΔΕΣΕΩΣ JOINT CORNER	TEM. PCS 6	Σακούλα Bag	Άβαφο Unpainted	Αλουμίνιο Aluminium	EL 80 13
805 1.140		ΓΩΝΙΑ ΣΥΝΔΕΣΕΩΣ JOINT CORNER	TEM. PCS 10	Σακούλα Bag	Άβαφο Unpainted	Αλουμίνιο Aluminium	EL 800 1 EL 80 11 EL 8022
805 1.220		ΓΩΝΙΑ ΣΥΝΔΕΣΕΩΣ JOINT CORNER	TEM. PCS 6	Σακούλα Bag	Άβαφο Unpainted	Αλουμίνιο Aluminium	EL 800 1
805 1.320		ΓΩΝΙΑ ΣΥΝΔΕΣΕΩΣ JOINT CORNER	TEM. PCS 4	Σακούλα Bag	Άβαφο Unpainted	Αλουμίνιο Aluminium	EL 8002
8052.220		ΓΩΝΙΑ ΣΥΝΔΕΣΕΩΣ JOINT CORNER	TEM. PCS 6	Σακούλα Bag	Άβαφο Unpainted	Αλουμίνιο Aluminium	EL 80 11 EL 80 13 EL 8022
5430.110		ΓΩΝΙΑ ΣΥΝΔΕΣΕΩΣ JOINT CORNER	TEM. PCS 4	Σακούλα Bag	Άβαφο Unpainted	Αλουμίνιο Aluminium	EL 8002
5408.140		ΓΩΝΙΑ ΣΥΝΔΕΣΕΩΣ JOINT CORNER	TEM. PCS 6	Σακούλα Bag	Άβαφο Unpainted	Αλουμίνιο Aluminium	EL 8003
5408.300		ΓΩΝΙΑ ΣΥΝΔΕΣΕΩΣ JOINT CORNER	TEM. PCS 6	Σακούλα Bag	Άβαφο Unpainted	Αλουμίνιο Aluminium	EL 8003

ΚΩΔ. CODE	ΜΟΡΦΗ SHAPE	ΠΕΡΙΓΡΑΦΗ DESCRIPTION	ΣΥΣΚ/ΣΙΑ PACKAGE	ΔΙΑΣΤ.ΣΥΣΚ PACK DIMENTIONS	ΧΡΩΜΑ COLOR	ΥΛΙΚΟ MATERIAL	ΣΥΝΕΡΓΑΖΕΤΑΙ ΜΕ COMBINES WITH
AL.EX 2071		ΚΛΙΠ ΓΙΑ ΑΡΜΟΚΑΛΥΠΤΡΟ CLIP FOR OUTER COVER	TEM./ ΚΟΥΤΙ PCS/ BOX 200	Σακούλα Bag	Άβαφο Unpainted	Αλουμίνιο Aluminium	EL 800 1 EL 8002 EL 8003 EL 6772
GE.1201INOX		ΓΩΝΙΑ ΕΠΙΠΕΔΟΤΗΤΑΣ ALIGNMENT CORNER	TEM./ ΚΟΥΤΙ PCS/ BOX 200	Σακούλα Bag	Άβαφο Unpainted	Inox Έλασμα Inox Lamina	EL 8003
GE.1202INOX		ΓΩΝΙΑ ΕΠΙΠΕΔΟΤΗΤΑΣ ALIGNMENT CORNER	TEM./ ΚΟΥΤΙ PCS/ BOX 250	Σακούλα Bag	Άβαφο Unpainted	Inox Έλασμα Inox Lamina	EL 2080 EL 6772
LP.2001T		ΕΛΑΣΤΙΚΟ ΠΕΡΙΜΕΤΡΙΚΗΣ ΣΤΕΓΑΝΩΣΗΣ PERIMETRIC GASKET	260m	ΚΟΥΤΙ - BOX Μήκος x Ύψος x Πλάτος 60x 18x60 Length x Height x Width	Μαύρο Black	EPDM	Όλες τις Κάσες, Φύλλα Ταρ & Μπινί All Frames, Sashes, "T" profiles & Mullions
LF-8000		ΕΛΑΣΤΙΚΟ ΜΟΝΩΣΗΣ ΚΑΣΩΝ GASKET INSULATION FOR FRAMES	10m	Σακούλα Bag	Μαύρο Black	EPDM	EL 800 1 EL 8002 EL 8003
LT.1121EPDMD		ΕΞΩΤΕΡΙΚΟ ΕΛΑΣΤΙΚΟ ΥΑΛΩΣΗΣ ΔΙΑΚΕΝΟ ΚΑΛΥΨΗΣ 3,5- 4 mm EXTERNAL GLAZING GASKET 3,5- 4mm	90m	ΚΟΥΤΙ - BOX Μήκος x Ύψος x Πλάτος 60x 18x60 Length x Height x Width	Μαύρο Black	EPDM	Με όλες τις Κάσες, Φύλλα & Ταυ With all Frames, Sashes & "T" Profiles
LT.1060EPDM.M		ΕΣΩΤΕΡΙΚΟ ΕΛΑΣΤΙΚΟ ΥΑΛΩΣΗΣ ΔΙΑΚΕΝΟ ΚΑΛΥΨΗΣ 2- 3 mm INTERNAL GLAZING GASKET 2- 3mm	280m/ 10kg	ΡΟΛΟ Ø45 ROLL Ø45	Μαύρο Black	EPDM	Όλα τα Φύλλα & Ταρ All Frames & "T" profiles
LT.1061EPDM.M		ΕΣΩΤΕΡΙΚΟ ΕΛΑΣΤΙΚΟ ΥΑΛΩΣΗΣ ΔΙΑΚΕΝΟ ΚΑΛΥΨΗΣ 3- 4 mm INTERNAL GLAZING GASKET 3- 4mm	180m/ 10kg	ΡΟΛΟ Ø45 ROLL Ø45	Μαύρο Black	EPDM	Όλα τα Φύλλα & Ταρ All Frames & "T" profiles

Εξαρτήματα για όλους τους τύπους κατασκευών / Accessories for all constructions types

ΚΩΔ. CODE	ΜΟΡΦΗ SHAPE	ΠΕΡΙΓΡΑΦΗ DESCRIPTION	ΣΥΣΚ/ΣΙΑ PACKAGE	ΔΙΑΣΤ.ΣΥΣΚ PACK DIMENTIONS	ΧΡΩΜΑ COLOR	ΥΛΙΚΟ MATERIAL	ΣΥΝΕΡΓΑΖΕΤΑΙ ΜΕ COMBINES WITH
LT1062EPDM.M		ΕΣΩΤΕΡΙΚΟ ΕΛΑΣΤΙΚΟ ΥΑΛΩΣΗΣ ΔΙΑΚΕΝΟ ΚΑΛΥΨΗΣ 4-5 mm INTERNAL GLAZING GASKET INTERVAL 4-5 mm	130m/ 10kg	ΡΟΛΟ Ø45 ROLL Ø45	Μαύρο Black	EPDM	Όλα τα Φύλλα & Ταρ All Frames & "T" profiles
LT1063EPDM.M		ΕΣΩΤΕΡΙΚΟ ΕΛΑΣΤΙΚΟ ΥΑΛΩΣΗΣ ΔΙΑΚΕΝΟ ΚΑΛΥΨΗΣ 5-6 mm INTERNAL GLAZING GASKET INTERVAL 5-6 mm	84m/ 10kg	ΡΟΛΟ Ø45 ROLL Ø45	Μαύρο Black	EPDM	Όλα τα Φύλλα & Ταρ All Frames & "T" profiles
LT1064EPDM.M		ΕΣΩΤΕΡΙΚΟ ΕΛΑΣΤΙΚΟ ΥΑΛΩΣΗΣ ΔΙΑΚΕΝΟ ΚΑΛΥΨΗΣ 6-7 mm INTERNAL GLAZING GASKET INTERVAL 6-7 mm	60m/ 10kg	ΡΟΛΟ Ø45 ROLL Ø45	Μαύρο Black	EPDM	Όλα τα Φύλλα & Ταρ All Frames & "T" profiles
BRM.7X8		ΒΟΥΡΤΣΑΚΙ ΣΤΕΓΑΝΩΣΗΣ ΜΕ ΜΕΜΒΡΑΝΗ 7X8 7X8 SEALING BRUSH WITH MEMBRANE	350m	ΡΟΛΟ Ø 50 ROLL Ø 50	Λευκό Γκρί Μαύρο White Grey Black		
LG.1121		ΕΛΑΣΤΙΚΗ ΓΩΝΙΑ GASKET CORNER	TMX./ PCS 50	Σακούλα Bag	Μαύρο Black	PTE	Το ελαστικό LT.1121EPMD.D The gasket LT.1121EPMD.D
PF.2000		ΤΑΠΑ ΑΠΟΡΡΟΗΣ PLUG FOR WATER OUTFLOW	TMX./ PCS 100	Σακούλα Bag	Μαύρο Black	PA	EL 8011 EL 8022 EL 8003
PF.2001		ΤΑΠΑ ΑΠΟΡΡΟΗΣ PLUG FOR WATER OUTFLOW	TMX./ PCS 200	Σακούλα Bag	Μαύρο Black	PA	EL 8011 EL 8022 EL 8003
PF.2002		ΤΑΠΑ ΑΠΟΡΡΟΗΣ PLUG FOR WATER OUTFLOW	TMX./ PCS 100	Σακούλα Bag	Μαύρο Black	PA	EL 8011 EL 8022 EL 8003

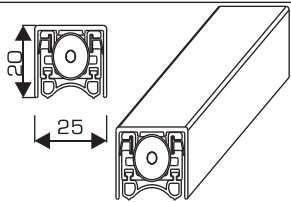
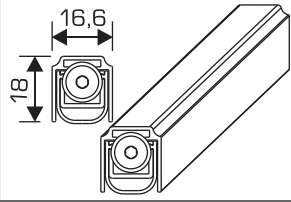
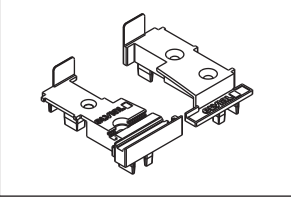
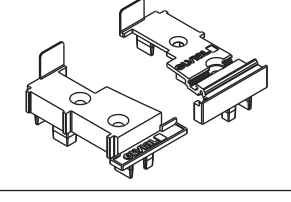
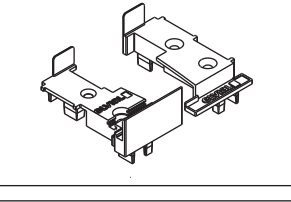
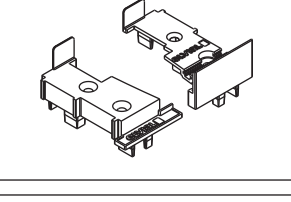
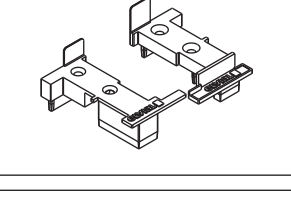
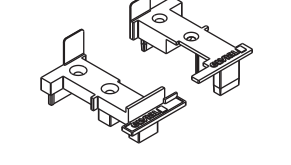
ΚΩΔ. CODE	ΜΟΡΦΗ SHAPE	ΑΝΑΛΥΤΙΚΟΣ ΚΩΔ. ΠΕΡΙΓΡΑΦΗ DESCRIPTION	ΣΥΣΚ/ΣΙΑ PACKAGE	ΔΙΑΣΤ.ΣΥΣΚ PACK DIMENSIONS	ΧΡΩΜΑ COLOR	ΥΛΙΚΟ MATERIAL	ΣΥΝΕΡΓΑΖΕΤΑΙ ΜΕ COMBINES WITH
WS.ASACA.		WS.ASACA.830 WS.ASACA.930 WS.ASACA.1030 WS.ASACA.1130 WS.ASACA.1230 ΓΙΑ ΕΙΣΟΔΟ ΑΝΟΙΓΟΜΕΝΗ ΠΡΟΣ ΤΑ ΜΕΣΑ/ FOR INWARDS OPENING ENTRANCE	ΤΕΜ./ΚΟΥΤΙ PCS/BOX 1	830 mm 930 mm 1030mm 1130mm 1230mm Μήκος/ Length	Αβαφο Unpainted	Αλουμίνιο Aluminium	EL 80 11
WS.ASPAL.		WS.ASPAL.830 WS.ASPAL.930 WS.ASPAL.1030 WS.ASPAL.1130 WS.ASPAL.1230 ΓΙΑ ΕΙΣΟΔΟ ΑΝΟΙΓΟΜΕΝΗ ΠΡΟΣ ΤΑ ΕΞ / FOR OUTWARDS OPENING ENTRANCE	ΤΕΜ./ΚΟΥΤΙ PCS/BOX 1	830 mm 930 mm 1030mm 1130mm 1230mm Μήκος/ Length	Αβαφο Unpainted	Αλουμίνιο Aluminium	EL 8022
P.806 1L		ΓΙΑ ΕΙΣΟΔΟ ΑΝΟΙΓΟΜΕΝΗ ΠΡΟΣ ΤΑ ΜΕΣΑ ΔΕΞΙΑ ΜΕ ΚΑΤΟΚΑΣΙ FOR INWARDS & TO THE RIGHT OPENING ENTRANCE WITH THRESHOLD	ΤΕΜ./ΚΟΥΤΙ PCS/BOX 1	Σακούλα Bag	Μαύρο Black	PA	EL 806 1
P.806 1R		ΓΙΑ ΕΙΣΟΔΟ ΑΝΟΙΓΟΜΕΝΗ ΠΡΟΣ ΤΑ ΜΕΣΑ ΑΡΙΣΤΕΡΑ ΜΕ ΚΑΤΟΚΑΣΙ FOR INWARDS & TO THE LEFT OPENING ENTRANCE WITH THRESHOLD	ΤΕΜ./ΚΟΥΤΙ PCS/BOX 1	Σακούλα Bag	Μαύρο Black	PA	EL 806 1
P.806 1LWS		ΓΙΑ ΕΙΣΟΔΟ ΑΝΟΙΓΟΜΕΝΗ ΠΡΟΣ ΤΑ ΜΕΣΑ ΔΕΞΙΑ ΜΕ ΑΝΕΜΟΦΡΑΚΤΗ FOR INWARDS & TO THE RIGHT OPENING ENTRANCE WITH WINDSHIELD	ΤΕΜ./ΚΟΥΤΙ PCS/BOX 1	Σακούλα Bag	Μαύρο Black	PA	EL 806 1
P.806 1RWS		ΓΙΑ ΕΙΣΟΔΟ ΑΝΟΙΓΟΜΕΝΗ ΠΡΟΣ ΤΑ ΜΕΣΑ ΑΡΙΣΤΕΡΑ ΜΕ ΑΝΕΜΟΦΡΑΚΤΗ FOR INWARDS & TO THE LEFT OPENING ENTRANCE WITH WINDSHIELD	ΤΕΜ./ΚΟΥΤΙ PCS/BOX 1	Σακούλα Bag	Μαύρο Black	PA	EL 806 1
P.8062L		ΓΙΑ ΕΙΣΟΔΟ ΑΝΟΙΓΟΜΕΝΗ ΠΡΟΣ ΤΑ ΕΞ ΔΕΞΙΑ ΜΕ ΚΑΤΟΚΑΣΙ FOR OUTWARDS & TO THE RIGHT OPENING ENTRANCE WITH THRESHOLD	ΤΕΜ./ΚΟΥΤΙ PCS/BOX 1	Σακούλα Bag	Μαύρο Black	PA	EL 8062
P.8062R		ΓΙΑ ΕΙΣΟΔΟ ΑΝΟΙΓΟΜΕΝΗ ΠΡΟΣ ΤΑ ΕΞ ΑΡΙΣΤΕΡΑ ΜΕ ΚΑΤΟΚΑΣΙ FOR OUTWARDS & TO THE LEFT OPENING ENTRANCE WITH THRESHOLD	ΤΕΜ./ΚΟΥΤΙ PCS/BOX 1	Σακούλα Bag	Μαύρο Black	PA	EL 8062

Εξαρτήματα για όλους τους τύπους κατασκευών / Accessories for all constructions types

ΚΩΔ. CODE	ΜΟΡΦΗ SHAPE	ΠΕΡΙΓΡΑΦΗ DESCRIPTION	ΣΥΣΚ/ΣΙΑ PACKAGE	ΔΙΑΣΤ.ΣΥΣΚ PACK DIMENTIONS	ΧΡΩΜΑ COLOR	ΥΛΙΚΟ MATERIAL	ΣΥΝΕΡΓΑΖΕΤΑΙ ΜΕ COMBINES WITH
P.8062LWS		ΓΙΑ ΕΙΣΟΔΟ ΑΝΟΙΓΟΜΕΝΗ ΠΡΟΣ ΤΑ ΕΞΩ ΔΕΞΙΑ ΜΕ ΑΝΕΜΟΦΡΑΚΤΗ FOR OUTWARDS & TO THE RIGHT OPENING ENTRANCE WITH WINDSHIELD	TEM./ΚΟΥΤΙ PCS/BOX 1	Σακούλα Bag	Μαύρο Black	PA	EL 8062
P.8062RWS		ΓΙΑ ΕΙΣΟΔΟ ΑΝΟΙΓΟΜΕΝΗ ΠΡΟΣ ΤΑ ΕΞΩ ΑΡΙΣΤΕΡΑ ΜΕ ΑΝΕΜΟΦΡΑΚΤΗ FOR OUTWARDS & TO THE LEFT OPENING ENTRANCE WITH WINDSHIELD	TEM./ΚΟΥΤΙ PCS/BOX 1	Σακούλα Bag	Μαύρο Black	PA	EL 8062
P.8076		ΤΑΠΑ ΚΑΤΩΚΑΣΙ THRESHOLD'S COVER	TEM./ΚΟΥΤΙ PCS/BOX 1	Σακούλα Bag	Μαύρο Black	PA	EL 8076
P.8077		ΤΑΠΑ ΚΑΤΩΚΑΣΙ THRESHOLD'S COVER	TEM./ΚΟΥΤΙ PCS/BOX 1	Σακούλα Bag	Μαύρο Black	PA	EL 8077
P.8071		ΤΑΠΑ ΠΡΟΣΘΕΤΟ ΦΥΛΛΟΥ COVER FOR SASH'S ADDITIONAL PROFILE	TEM./ΚΟΥΤΙ PCS/BOX 1	Σακούλα Bag	Μαύρο Black	PA	EL 8070 EL 8071
P.CCE8000		ΤΑΠΑ ΣΤΕΓΑΝΩΣΗΣ ΚΑΣΩΝ COVER FOR FRAMES' WATERPROOF	TEM./ΚΟΥΤΙ PCS/BOX 1	Σακούλα Bag	Μαύρο Black	TPE	EL 8001 EL 8002
B 7330 9001		ΡΟΖΕΤΑ ΑΣΦΑΛΕΙΑΣ SAFETY ROSSETE	TEM./ΚΟΥΤΙ PCS/BOX 1	ΚΟΥΤΙ - BOX Μήκος x Ύψος x Πλάτος Length x Height x Width	Inox	Ανοξείδωτο Ατσάλι Stainless Steel	
FP3722A140		ΣΥΡΤΗΣ 2ου ΦΥΛΛΟΥ LATCHE	TEM./ΚΟΥΤΙ PCS/BOX 1	Σακούλα Bag	Ασημί Silver	Zamac	

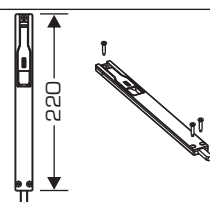
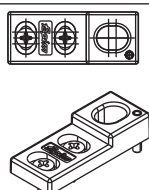
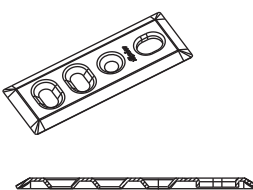
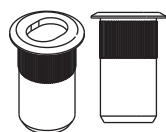
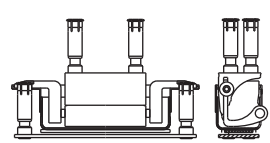
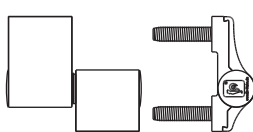
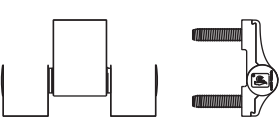
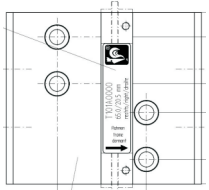
ΚΩΔ. CODE	ΜΟΡΦΗ SHAPE	ΠΕΡΙΓΡΑΦΗ DESCRIPTION	ΣΥΣΚ/ΣΙΑ PACKAGE	ΔΙΑΣΤ.ΣΥΣΚ PACK DIMENTIONS	ΧΡΩΜΑ COLOR	ΥΛΙΚΟ MATERIAL	ΣΥΝΕΡΓΑΖΕΤΑΙ ΜΕ COMBINES WITH
FP3722B220		ΣΥΡΤΗΣ 2ου ΦΥΛΛΟΥ LATCH	TEM./ΚΟΥΤΙ PCS/BOX 1	Σακούλα Bag	Ασημί Silver	Zamac	
FP3733		ΑΝΤΙΚΡΥΣΜΑ ΣΥΡΤΗ 2ου ΦΥΛΛΟΥ LATCH LOCKING PLATE	TEM./ΚΟΥΤΙ PCS/BOX 1	Σακούλα Bag	Ασημί Silver	Zamac	
FP3734		ΑΝΤΙΚΡΥΣΜΑ ΣΥΡΤΗ 2ου ΦΥΛΛΟΥ LATCH LOCKING PLATE	TEM./ΚΟΥΤΙ PCS/BOX 1	Σακούλα Bag	Ασημί Silver	Ανοξείδωτος Χάλυβας Stainless Steel	
FP3738		ΑΝΤΙΚΡΥΣΜΑ ΣΥΡΤΗ 2ου ΦΥΛΛΟΥ LATCH LOCKING PLATE	TEM./ΚΟΥΤΙ PCS/BOX 1	Σακούλα Bag	Ασημί Silver	Zamac	
V3511006		ΚΡΥΦΟΣ ΜΕΝΤΕΣΣ CONCEALED HINGE	TEM./ΚΟΥΤΙ PCS/BOX 1		Ασημί Silver	Ανοξείδωτος Χάλυβας Stainless Steel	
A.90**..W000		A.90 11.W000 A.90 1G.W000 A.90 1R.W000 A.90 18.W000 ΔΙΠΛΟΣ ΜΕΝΤΕΣΣ TURBAND4/DOUBLE(2 PTS) TURBAND4 HINGE	TEM./ΚΟΥΤΙ PCS/BOX 1		Ασημί Ανοδ./ Silver Anodized Λευκό/ White Σκ. Καφέ/ Dark Brown Μαύρη Ανοδ./ Black Anodized	Αλουμίνιο Aluminium	EL 80 11
A.95**..W000		A.95 11.W000 A.95 1G.W000 A.95 1R.W000 A.95 18.W000 ΤΡΙΠΛΟΣ ΜΕΝΤΕΣΣ TURBAND4/TRIPLE (3 PTS) TURBAND4 HINGE	TEM./ΚΟΥΤΙ PCS/BOX 1		Ασημί Ανοδ./ Silver Anodized Λευκό/ White Σκ. Καφέ/ Dark Brown Μαύρη Ανοδ./ Black Anodized	Αλουμίνιο Aluminium	
T101A0000		ΣΑΜΠΛΟΝ ΓΙΑ ΔΙΠΛΟ ΜΕΝΤΕΣΣ SABLON FOR DOUBLE HINGE	TEM./ΚΟΥΤΙ PCS/BOX 1			Χάλυβας Steel	

Εξαρτήματα για όλους τους τύπους κατασκευών / Accessories for all constructions types

ΚΩΔ. CODE	ΜΟΡΦΗ SHAPE	ΠΕΡΙΓΡΑΦΗ DESCRIPTION	ΣΥΣΚ/ΣΙΑ PACKAGE	ΔΙΑΣΤ.ΣΥΣΚ PACK DIMENTIONS	ΧΡΩΜΑ COLOR	ΥΛΙΚΟ MATERIAL	ΣΥΝΕΡΓΑΖΕΤΑΙ ΜΕ COMBINES WITH
T15.1A0000		ΣΑΜΠΛΟΝ ΓΙΑ ΤΡΙΓΙΛΟ ΜΕΝΤΕΣΕ SABLON FOR TRIPLE HINGE	TEM./ΚΟΥΤΙ PCS/BOX 1			Χάλυβας Steel	
MG.F8000		ΜΑΧΑΙΡΙΑ ΓΩΝΙΑΣΤΡΑΣ ΚΑΣΩΝ ΓΙΑ ΓΙΑ ΓΩΝΙΑΣΤΡΕΣ ΤΥΠΟΥ ALVIT- URBAN FRAMES' KNIVES FOR TYPE ALVIT- URBAN CRIMPING MACHINES	TEM./ΚΟΥΤΙ PCS/BOX 1	Σακούλα Bag	Άβαφο Unpainted	Χάλυβας Steel	
MG.F8000PR		ΜΑΧΑΙΡΙΑ ΓΩΝΙΑΣΤΡΑΣ ΚΑΣΩΝ ΓΙΑ ΓΙΑ ΓΩΝΙΑΣΤΡΕΣ ΤΥΠΟΥ PRESTA- ELLIMATEC- RAPID FRAMES' KNIVES FOR TYPE PRESTA- ELLIMATEC- RAPID CRIMPING MACHINES	TEM./ΚΟΥΤΙ PCS/BOX 1	Σακούλα Bag	Άβαφο Unpainted	Χάλυβας Steel	
MG.F8000ALV		ΜΑΧΑΙΡΙΑ ΓΩΝΙΑΣΤΡΑΣ ΚΑΣΩΝ ΓΙΑ ΓΙΑ ΓΩΝΙΑΣΤΡΕΣ ΤΥΠΟΥ ELVIAL FRAMES' KNIVES FOR TYPE ELVIAL CRIMPING MACHINES	TEM./ΚΟΥΤΙ PCS/BOX 1	Σακούλα Bag	Άβαφο Unpainted	Χάλυβας Steel	
MG.F8000.TK		ΜΑΧΑΙΡΙΑ ΓΩΝΙΑΣΤΡΑΣ ΚΑΣΩΝ ΓΙΑ ΓΙΑ ΓΩΝΙΑΣΤΡΕΣ ΤΥΠΟΥ TEKNA FRAMES' KNIVES FOR TYPE TEKNA CRIMPING MACHINES	TEM./ΚΟΥΤΙ PCS/BOX 1	Σακούλα Bag	Άβαφο Unpainted	Χάλυβας Steel	
MG.S8000		ΜΑΧΑΙΡΙΑ ΓΩΝΙΑΣΤΡΑΣ ΦΥΛΛΟΥ ΓΙΑ ΓΩΝΙΑΣΤΡΕΣ ΤΥΠΟΥ ALVIT- URBAN SASHES' KNIVES FOR TYPE ALVIT- URBAN CRIMPING MACHINES	TEM./ΚΟΥΤΙ PCS/BOX 1	Σακούλα Bag	Άβαφο Unpainted	Χάλυβας Steel	
MG.S8000PR		ΜΑΧΑΙΡΙΑ ΓΩΝΙΑΣΤΡΑΣ ΦΥΛΛΩΝ ΓΙΑ ΓΙΑ ΓΩΝΙΑΣΤΡΕΣ ΤΥΠΟΥ PRESTA- ELLIMATEC- RAPID SASHES' KNIVES FOR TYPE PRESTA- ELLIMATEC- RAPID CRIMPING MACHINES	TEM./ΚΟΥΤΙ PCS/BOX 1	Σακούλα Bag	Άβαφο Unpainted	Χάλυβας Steel	
MG.S8000.ALV		ΜΑΧΑΙΡΙΑ ΓΩΝΙΑΣΤΡΑΣ ΦΥΛΛΩΝ ΓΙΑ ΓΙΑ ΓΩΝΙΑΣΤΡΕΣ ΤΥΠΟΥ ELVIAL SASHES' KNIVES FOR TYPE ELVIAL CRIMPING MACHINES	TEM./ΚΟΥΤΙ PCS/BOX 1	Σακούλα Bag	Άβαφο Unpainted	Χάλυβας Steel	

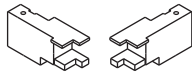
ΚΩΔ. CODE	ΜΟΡΦΗ SHAPE	ΠΕΡΙΓΡΑΦΗ DESCRIPTION	ΣΥΣΚ/ΣΙΑ PACKAGE	ΔΙΑΣΤ.ΣΥΣΚ PACK DIMENSIONS	ΧΡΩΜΑ COLOR	ΥΛΙΚΟ MATERIAL	ΣΥΝΕΡΓΑΖΕΤΑΙ ΜΕ COMBINES WITH
MG.S8000.TK		ΜΑΧΑΙΡΙΑ ΓΩΝΙΑΣΤΡΑΣ ΦΥΛΛΩΝ ΓΙΑ ΤΙΣ ΓΩΝΙΑΣΤΡΕΣ ΤΥΠΟΥ TEKNA SASHES' KNIVES FOR TYPE TEKNA CRIMPING MACHINES	ΤΕΜ./ΚΟΥΤΙ PCS/BOX 1	Σακούλα Bag	Άβαφο Unpainted	Χάλυβας Steel	

ΚΥΛΙΝΔΡΟΙ CYLINDERS	ΔΙΑΣΤΑΣΕΙΣ DIMENSIONS	8800 ΟΙΚ. ΣΕΙΡΑ 8800 ECONOMIC LINE	5000 ΠΕΡΙΣΣΟΤΕΡΗ ΑΣΦΑΛΕΙΑ 5000 MORE SAFETY	JANUS 45 ΚΟΡΥΦΑΙΑ ΑΣΦΑΛΕΙΑ JANUS 45 MAXIMUM SAFETY
	35- 55 35- 65 35- 70 40- 55 40- 65 40- 70	B 8800 0508 B 8800 0510 B 8800 0511 B 8800 0516 B 8800 0518 B 8800 0519	B 5012 0046 B 5012 0048 B 5012 0049 B 5012 0066 B 5012 0068 B 5012 0069	B 4512 35/55 B 4512 35/65 B 4512 35/70 B 4512 40/55 B 4512 40/65 B 4512 40/70

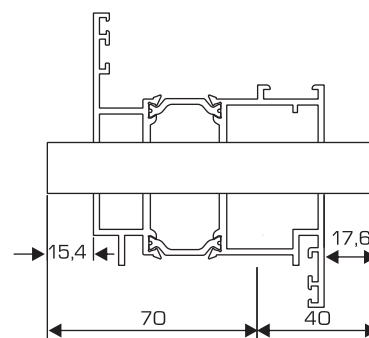
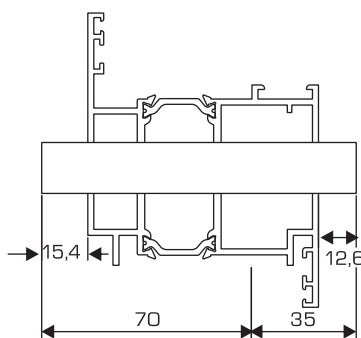
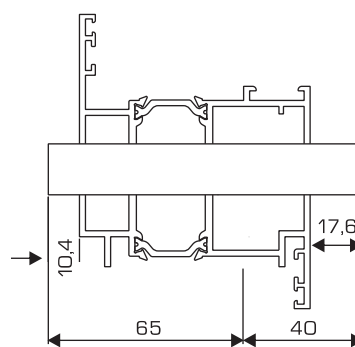
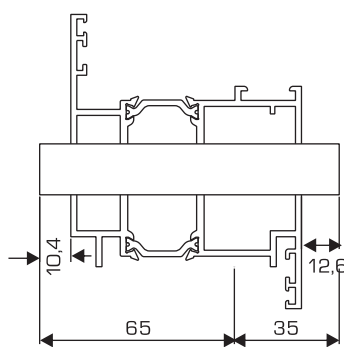
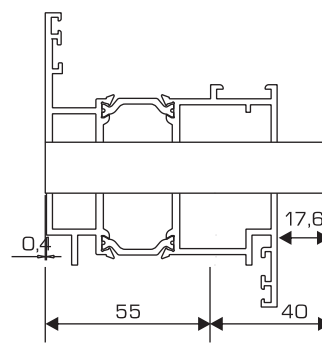
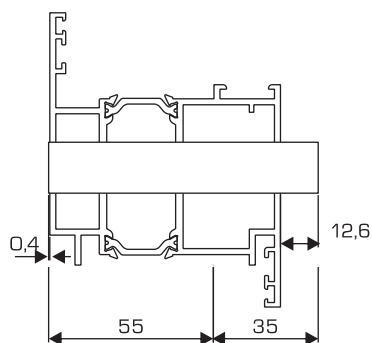
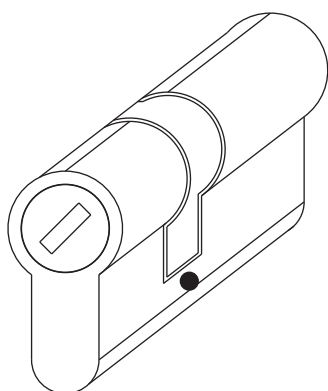

TURBAND 4	ΜΕΓΙΣΤΟ ΒΑΡΟΣ ΦΥΛΛΟΥ ΜΕ ΧΡΗΣΗ ΔΙΠΛΟΥ ΜΕΝΤΕΣΕ MAXIMUM SASH WEIGHT WHEN USING DOUBLE HINGE	180kg	Για πλάτος φύλλου μεγαλύτερο από 850mm επιβάλλεται η τοποθέτηση τρίτου μεντεσέ
	ΜΕΓΙΣΤΟ ΒΑΡΟΣ ΦΥΛΛΟΥ ΜΕ ΧΡΗΣΗ ΤΡΙΠΛΟΥ ΜΕΝΤΕΣΕ MAXIMUM SASH WEIGHT WHEN USING TRIPLE HINGE	220kg	For wider than 850mm sash's width, a third hinge is necessary
	ΜΕΓΙΣΤΟ ΠΛΑΤΟΣ ΦΥΛΛΟΥ MAXIMUM SASH WIDTH	1300mm	Για ύψος φύλλου μεγαλύτερο από 2000mm επιβάλλεται η τοποθέτηση τρίτου μεντεσέ For taller than 2000mm sash's height, a third hinge is necessary
	ΜΕΓΙΣΤΟ ΥΨΟΣ ΦΥΛΛΟΥ MAXIMUM SASH HEIGHT	2300mm	
	ΜΕΓΙΣΤΟ ΠΛΑΤΟΣ ΜΟΝΟΦΥΛΛΗΣ ΕΙΣΟΔΟΥ MAXIMUM HEIGHT FOR A SINGLE- SASH ENTRANCE	1400mm	
	ΜΕΓΙΣΤΟ ΠΛΑΤΟΣ ΔΙΦΥΛΛΗΣ ΕΙΣΟΔΟΥ MAXIMUM WIDTH FOR A DOUBLE- SASH ENTRANCE	2700mm	Ο τρίτος μεντεσές τοποθετείται 150mm χαμηλότερα από τον επάνω
	ΜΕΓΙΣΤΟ ΥΨΟΣ ΕΙΣΟΔΟΥ MAXIMUM HEIGHT OF ENTRANCE	2350mm	The third hinge should be placed 150mm below the top one

VL- Band AL	Μέγιστο Βάρος Φύλλου για μεντεσέ VL- Band AL συναρτήσει των διαστάσεων Maximum Sash's Weight of VL- Band AL hinge, based on dimentions							
2500	150 kg	150 kg	150 kg	150 kg	145 kg	140 kg	130 kg	125 kg
2450	150 kg	150 kg	150 kg	150 kg	140 kg	135 kg	130 kg	125 kg
2400	150 kg	150 kg	150 kg	145 kg	135 kg	130 kg	125 kg	120 kg
2350	150 kg	150 kg	145 kg	140 kg	130 kg	125 kg	120 kg	115 kg
2300	150 kg	150 kg	140 kg	135 kg	130 kg	125 kg	120 kg	115 kg
2250	150 kg	145 kg	135 kg	130 kg	125 kg	120 kg	115 kg	110 kg
2200	145 kg	140 kg	135 kg	125 kg	120 kg	115 kg	110 kg	105 kg
2150	140 kg	135 kg	130 kg	125 kg	120 kg	115 kg	110 kg	105 kg
2100	135 kg	130 kg	125 kg	120 kg	115 kg	110 kg	105 kg	100 kg
2050	130 kg	130 kg	120 kg	115 kg	110 kg	105 kg	100 kg	95 kg
2000	130 kg	125 kg	120 kg	110 kg	105 kg	105 kg	100 kg	95 kg
	1000	1050	1100	1150	1200	1250	1300	1350
	Πλάτος Φύλλου (mm)							

VL- Band AL	ΜΕΓΙΣΤΟ ΠΛΑΤΟΣ ΦΥΛΛΟΥ MAXIMUM SASH WIDTH	1350mm	Για πλάτος φύλλου μεγαλύτερο από 1000mm επιβάλλεται η τοποθέτηση τρίτου μεντεσέ
	ΜΕΓΙΣΤΟ ΥΨΟΣ ΦΥΛΛΟΥ MAXIMUM SASH HEIGHT	2500mm	For wider than 1000mm sash's width, a third hinge is necessary
	ΜΕΓΙΣΤΟ ΠΛΑΤΟΣ ΜΟΝΟΦΥΛΛΗΣ ΕΙΣΟΔΟΥ MAXIMUM HEIGHT FOR A SINGLE- SASH ENTRANCE	1450mm	Για ύψος φύλλου μεγαλύτερο από 2200mm επιβάλλεται η τοποθέτηση τρίτου μεντεσέ For taller than 2200mm sash's height, a third hinge is necessary
	ΜΕΓΙΣΤΟ ΠΛΑΤΟΣ ΔΙΦΥΛΛΗΣ ΕΙΣΟΔΟΥ MAXIMUM WIDTH FOR A DOUBLE- SASH ENTRANCE	2800mm	Ο τρίτος μεντεσές τοποθετείται 260mm χαμηλότερα από τον επάνω
	ΜΕΓΙΣΤΟ ΥΨΟΣ ΕΙΣΟΔΟΥ MAXIMUM HEIGHT OF ENTRANCE	2550mm	The third hinge should be placed 260mm below the top one

ΚΛΕΙΔΑΡΙΑ- LOCK 35/92/24 Automatic 2

Για Κάσα/ For Frame G6295 150008 (24 X 6)
Για Μπινί/ For Adjoining Profile G63 11060008 (24 X 8)



Για Κάσα/ For Frame G6295 1300L/R 1 (24 X 6)
Για Μπινί/ For Adjoining Profile G63 11030 1L/R 1 (24 X 8)



Για Κάσα/ For Frame G6295 150008 (24 X 6)
Για Μπινί/ For Adjoining Profile G63 11060008 (24 X 8)

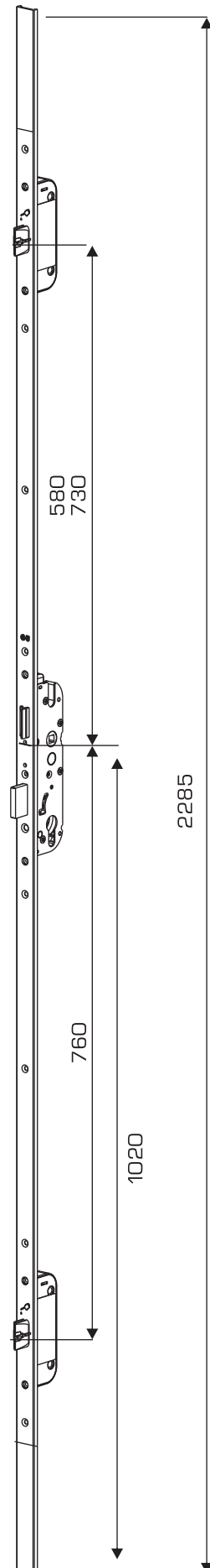

G6290403 10 1 (2285 mm)

ΚΛΕΙΔΑΡΙΑ- LOCK 35/92/24 Automatic 4

Για Κάσα/ For Frame G63 1965000 1 (24 X 6)
 Για Μπινί/ For Adjoining Profile G63 1966000 1 (24 X 8)



Για Κάσα/ For Frame G6295 1300L/R1 (24 X 6)
 Για Μπινί/ For Adjoining Profile G63 11030 1L/R1 (24 X 8)



Για Κάσα/ For Frame G63 1965000 1 (24 X 6)
 Για Μπινί/ For Adjoining Profile G63 1966000 1 (24 X 8)

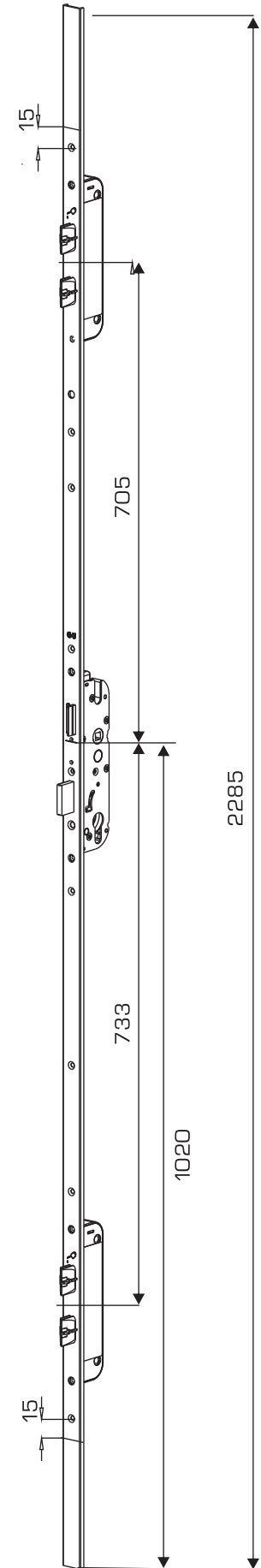

G6331131101 (2285 mm)

ΚΛΕΙΔΑΡΙΑ 35/92/24 Automatic 2
ΣΕ ΣΥΝΔΙΑΣΜΟ ΜΕ ΚΛΕΙΣΤΙΚΟ ΜΗΧΑΝΙΣΜΟ 2ου ΦΥΛΛΟΥ
LOCK 35/92/24 Automatic 2
WITH REBATE SHOOT BOLT AND EXTENSION PIECES

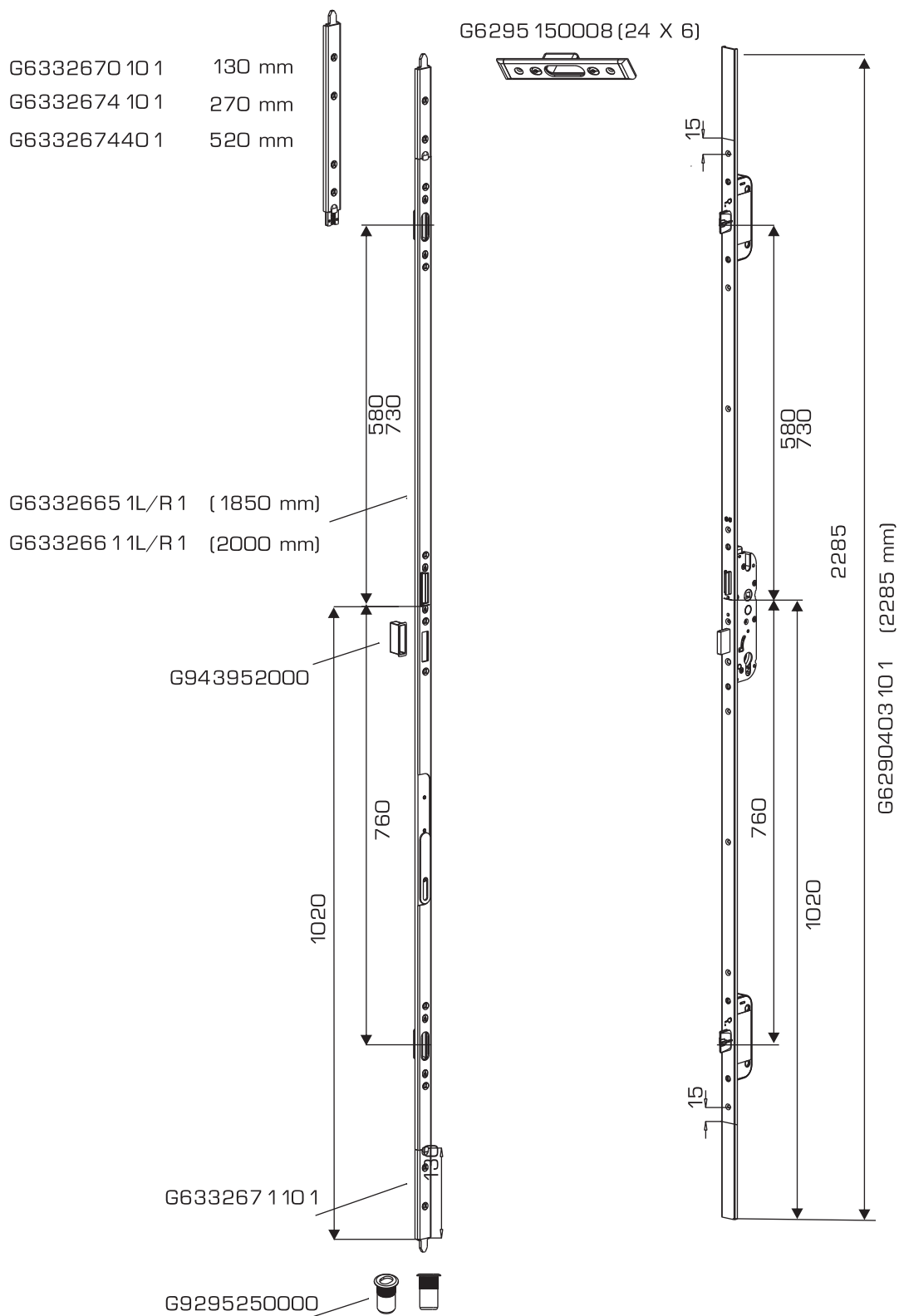

EL - 8000



■	Συνοπτικά προφίλ - Synoptic profiles
■	Προφίλ - Profiles
■	Τομές - Sections
■	Κοπές - Cuttings
■	Εξαρτήματα - Accessories
■	Κατεργασίες - Constructions' Specifications
■	3d's

Τοποθέτηση κρυφου μεντεσε
VL -Band AL σε είσοδο
ανοιγόμενη προς τα μέσα

Placing the concealed hinge
VL -Band AL to an
inwards opening entrance

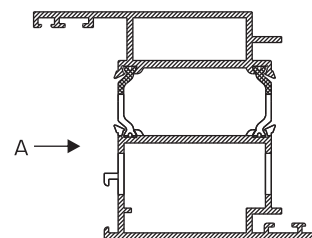
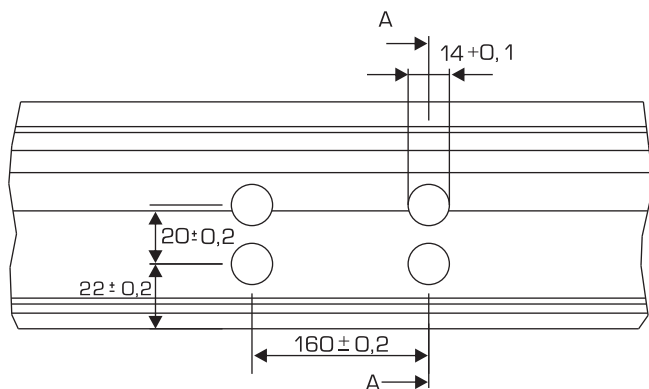
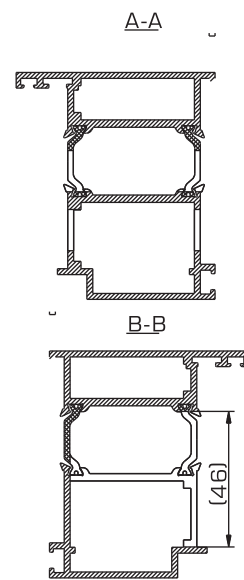
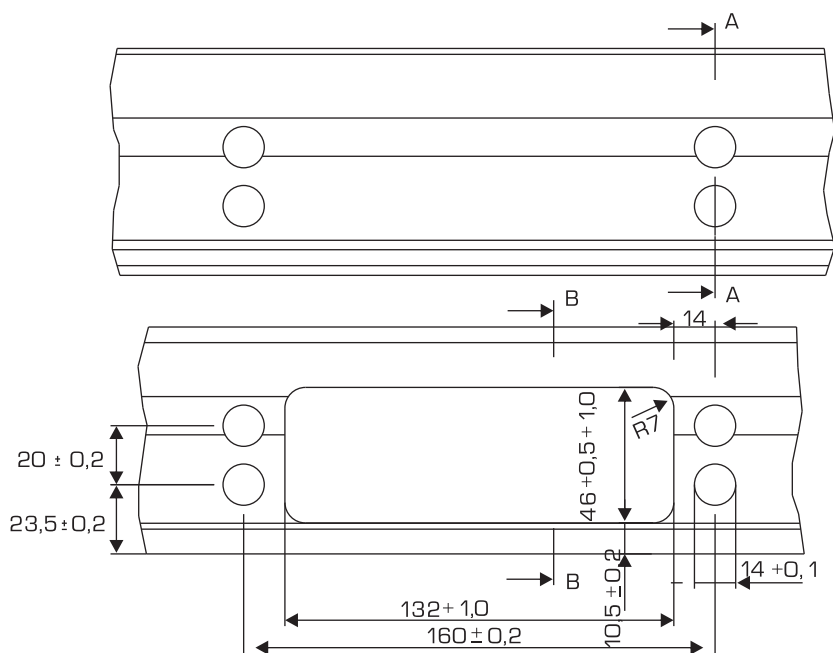
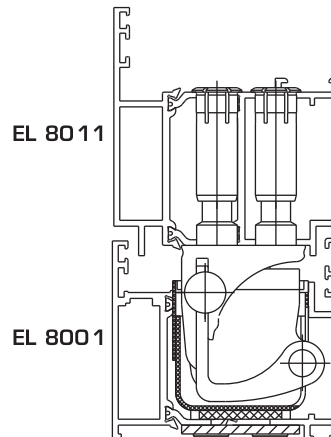
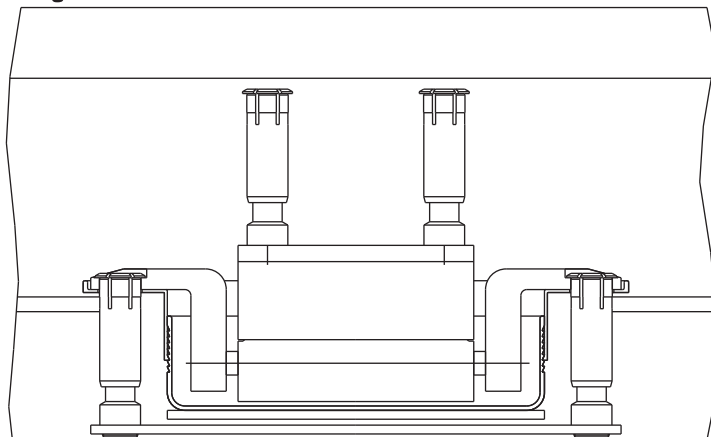

Αποστάσεις κατεργασιών για
τοποθέτηση κρυφού μεντεσέ για είσοδο
ανοιγόμενη προς τα μέσα με κατωκάσι

Placing a concealed hinge
to an inwards opening
entrance with threshold

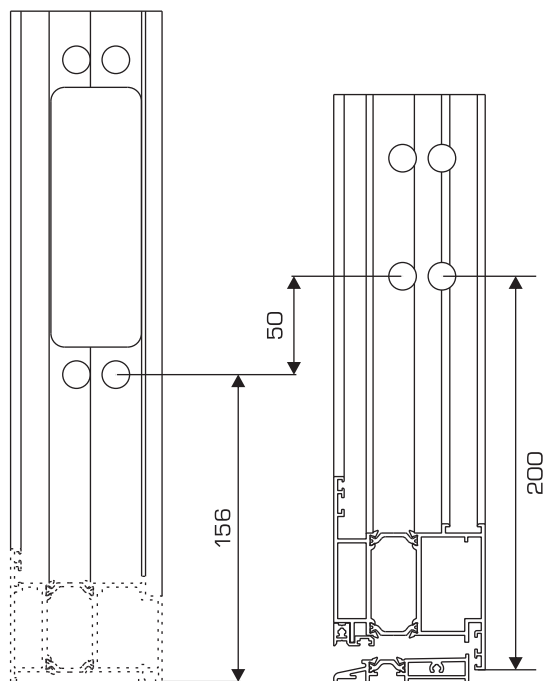
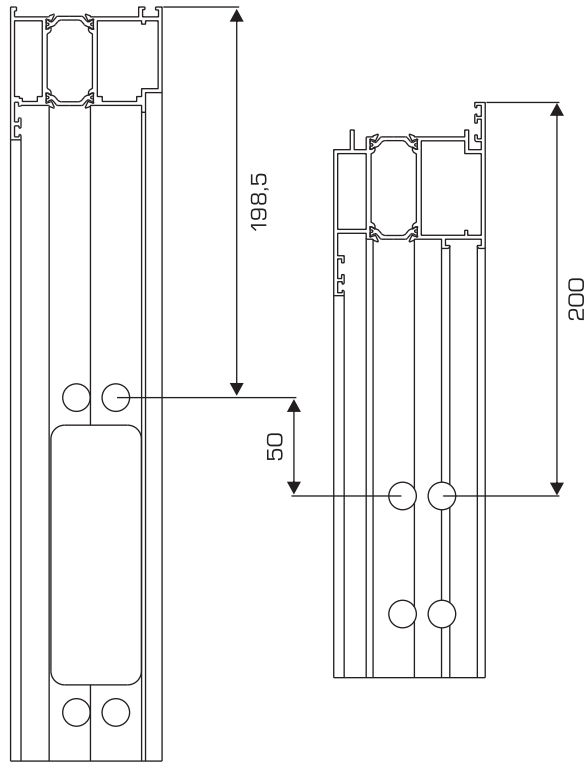

Αποστάσεις κατεργασιών για
τοποθέτηση κρυφού μεντεσέ VL- Band AL για είσοδο
ανοιγόμενη προς τα μέσα με ανεμοφράκτη

Placing the concealed hinge VL- Band AL
to an inwards opening
entrance with windshield

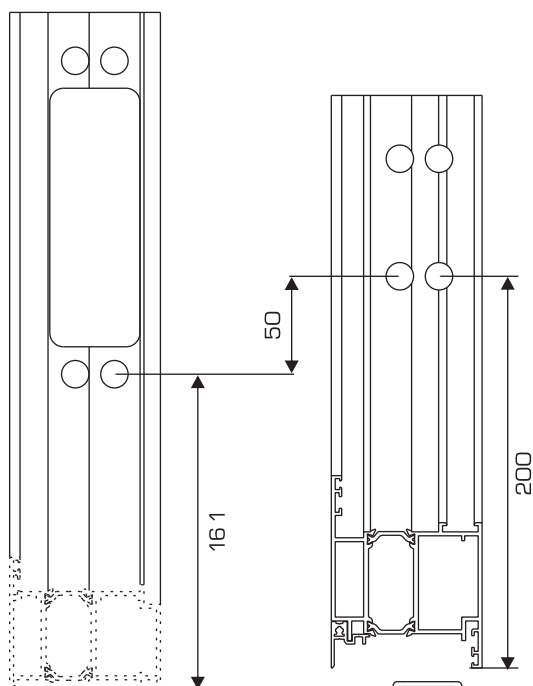
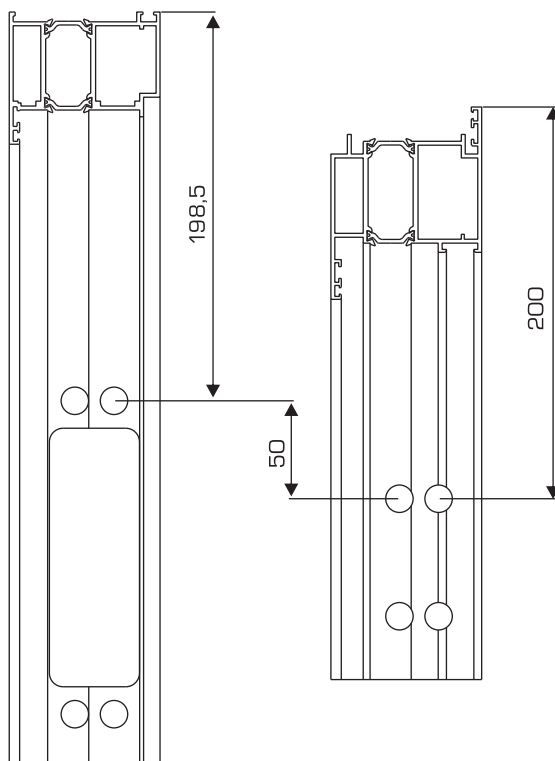

Τοποθέτηση κρυφού μεντεσε
VL -Band AL σε είσοδο
ανοιγόμενη προς τα έξω

Placing the concealed hinge
VL -Band AL to an
outwards opening entrance

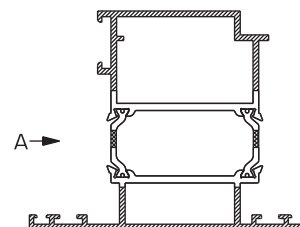
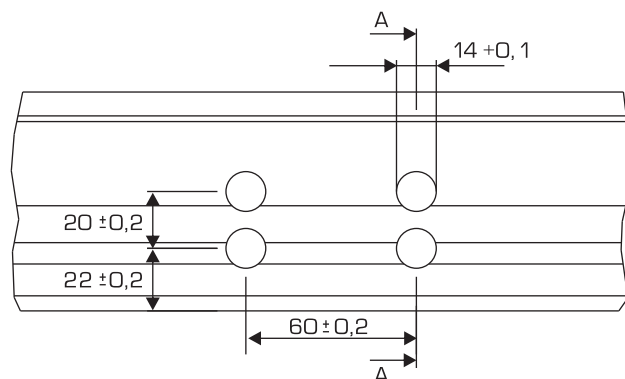
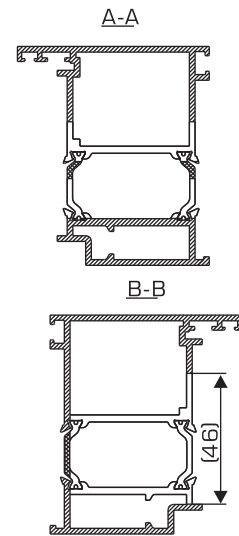
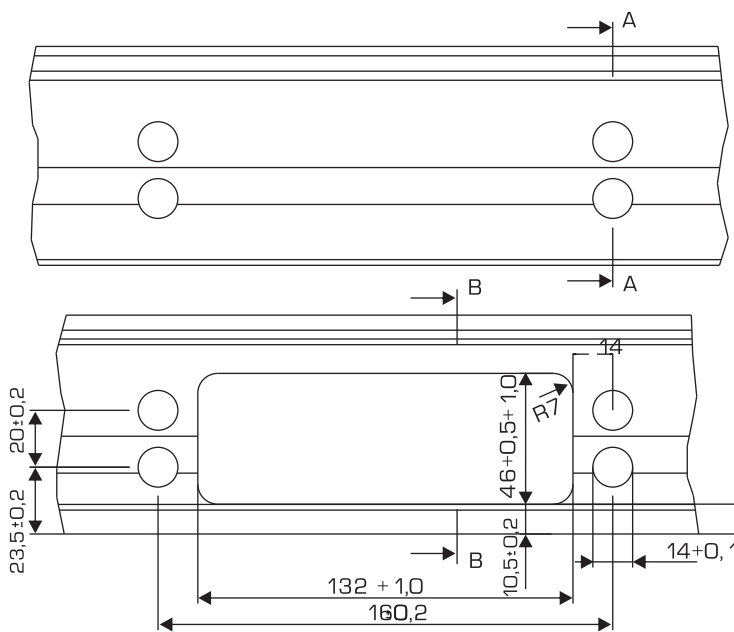
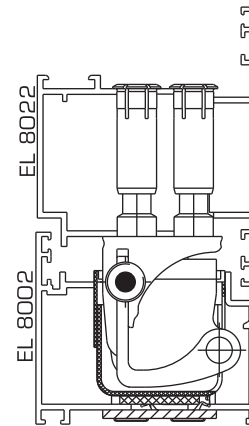
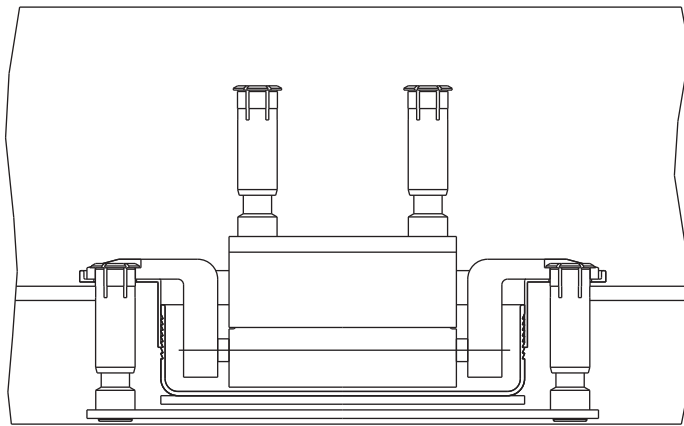

Αποστάσεις κατεργασιών για
τοποθέτηση κρυφού μεντεσέ VL- Band AL
για είσοδο ανοιγόμενη προς τα έξω με κατωκάσι

Placing the concealed hinge
VL- Band AL to an outwards opening
entrance with threshold

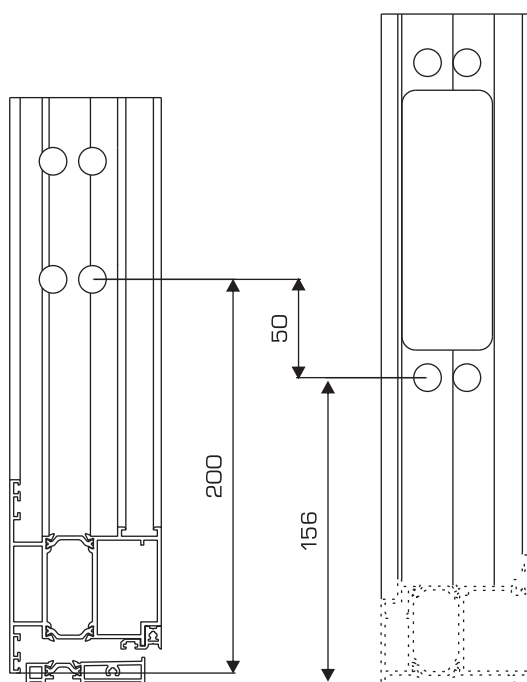
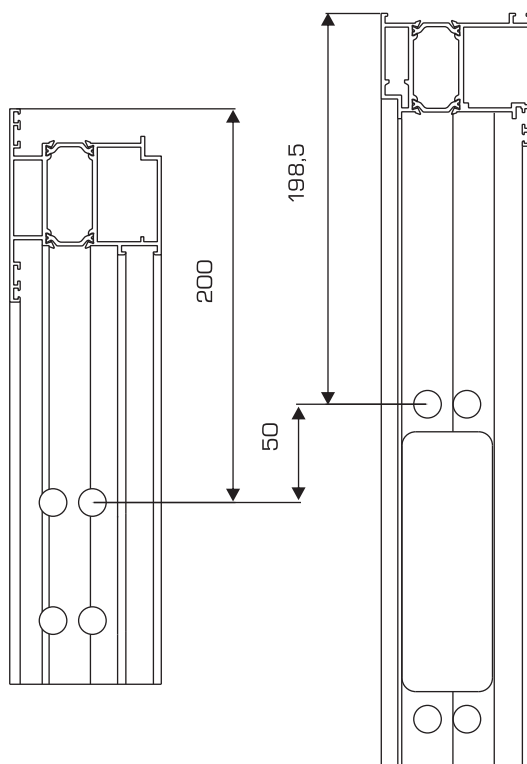

Αποστάσεις κατεργασίας για κρυφό μεντεσέ VI- Band AL
για είσοδο ανοιγόμενη προς τα έξω με ανεμοφράκτη

Dimensions for concealed hinge VL- Band AL
for an outwards opening door with windshield

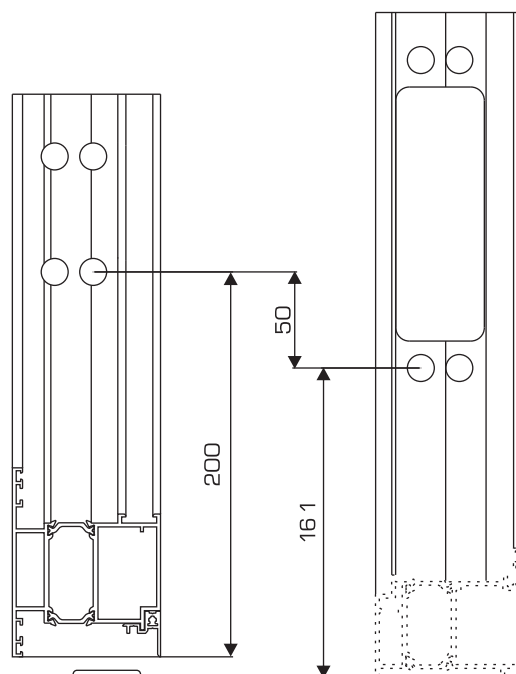
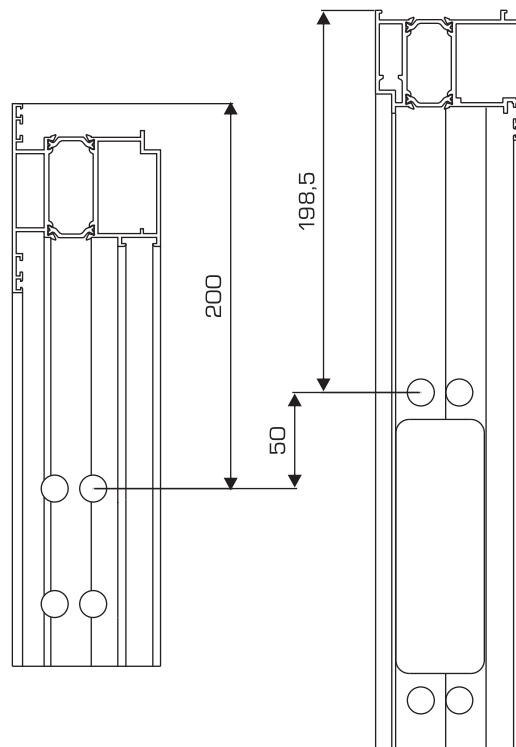

Αποστάσεις κατεργασίας για
διπλό και τριπλό μεντεσέ TURBAND 4
για είσοδο ανοιγόμενη προς τα μέσα

Dimensions for double and triple
TURBAND 4 hinge for an
inwards opening door

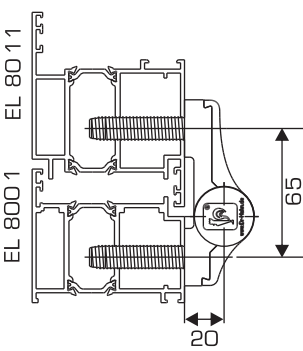
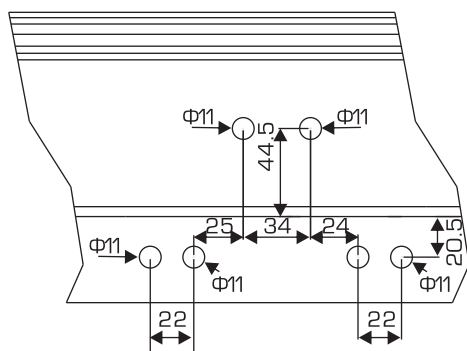
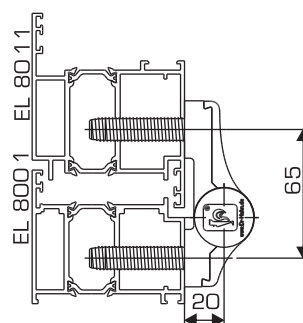
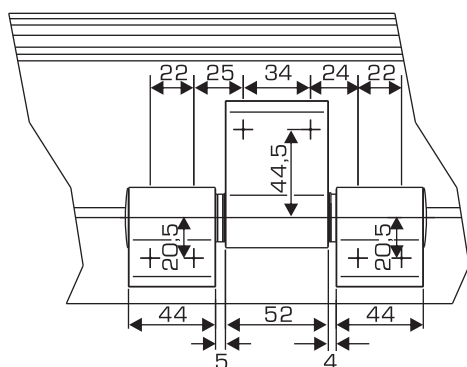
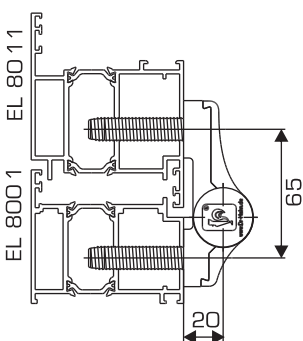
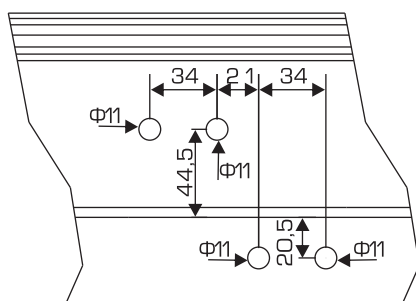
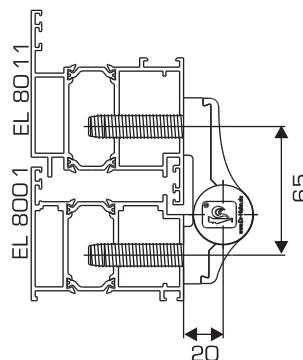
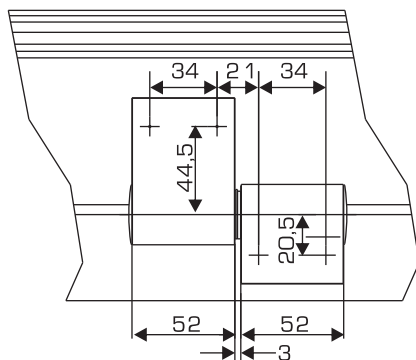

Τοποθέτηση διπλού μεντεσέ TURBAND 4
σε είσοδο ανοιγόμενη προς τα μέσα

Placing a double TURBAND 4 hinge
to an inwards opening entrance

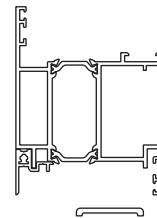
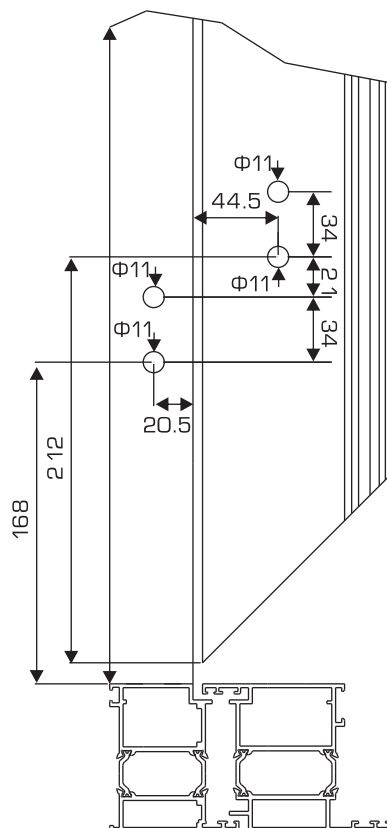
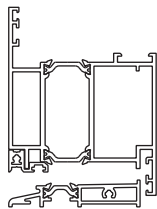
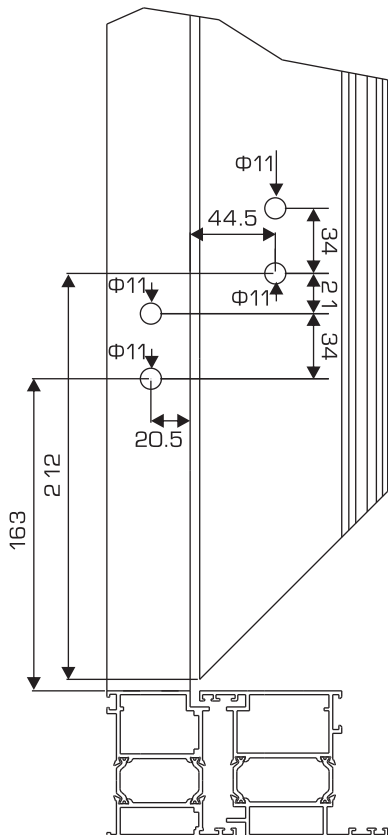
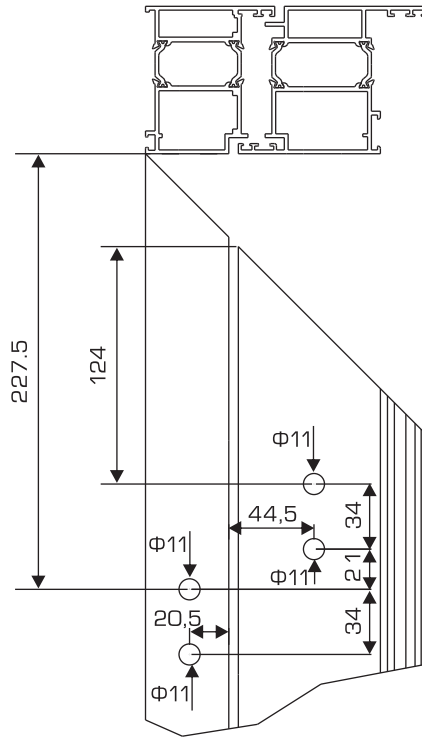
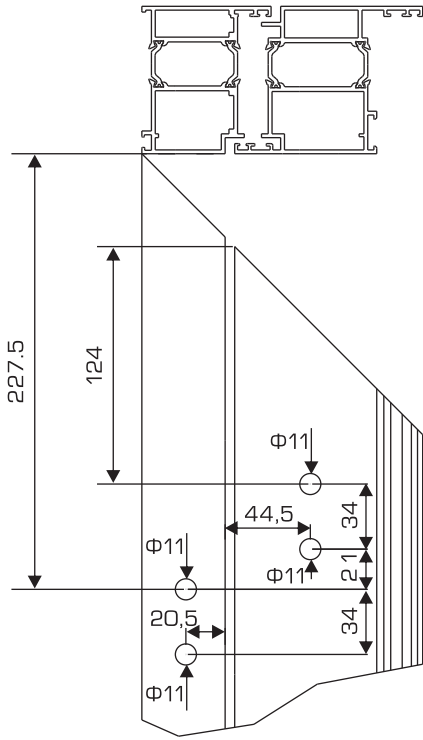

**Τοποθέτηση τριπλού μεντεσέ TURBAND 4
σε είσοδο ανοιγόμενη προς τα μέσα**
**Placing a triple TURBAND 4P hinge
to an inwards opening entrance**

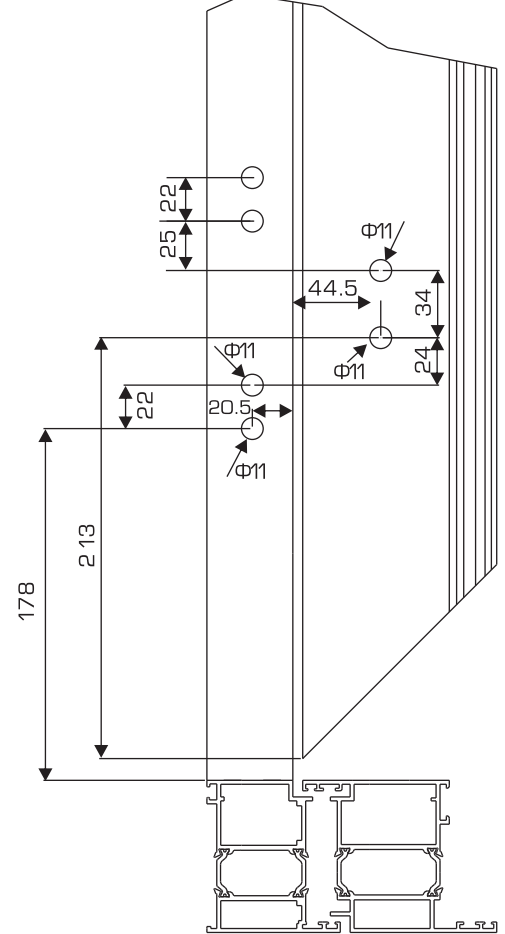
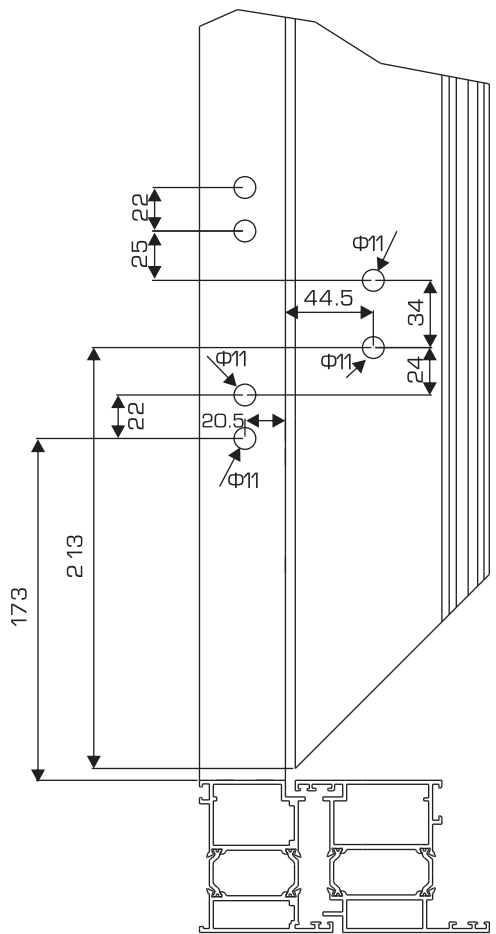
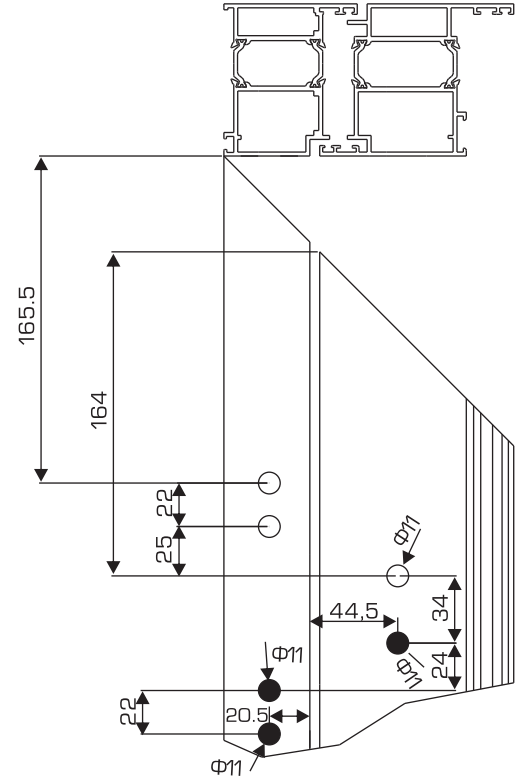
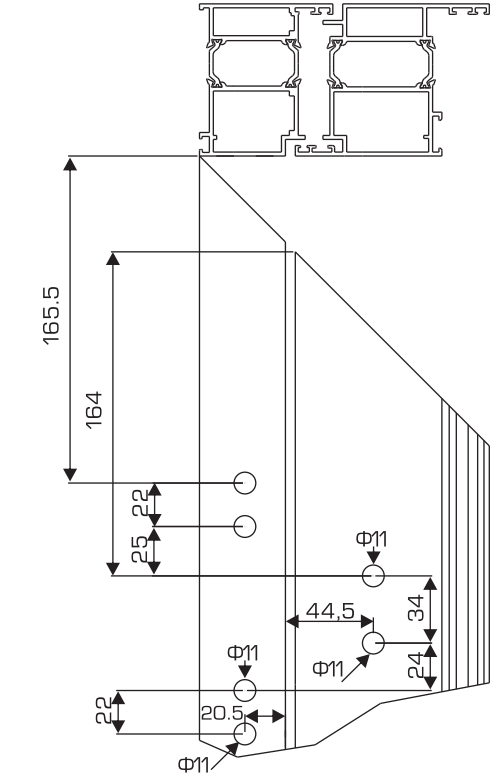

Αποστάσεις κατεργασίας για
διπλό και τριπλό μεντεσέ TURBAND 4
για είσοδο ανοιγόμενη προς τα έξω
Dimensions for double and triple
TURBAND 4 hinge for an
outwards opening door

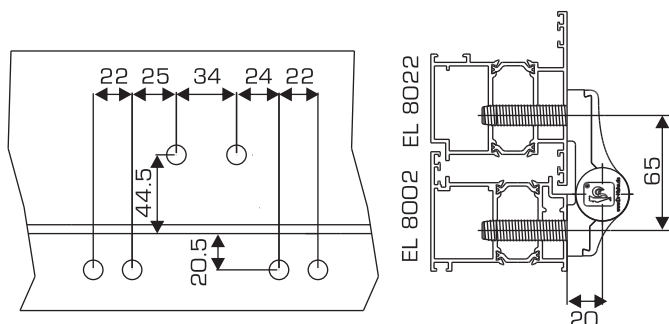
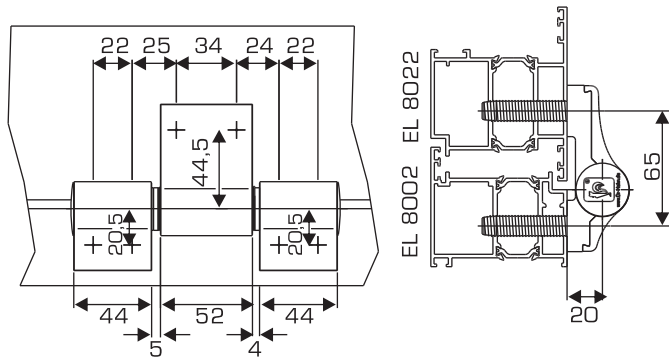
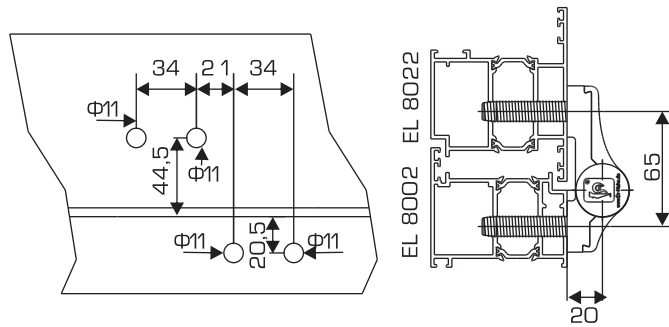
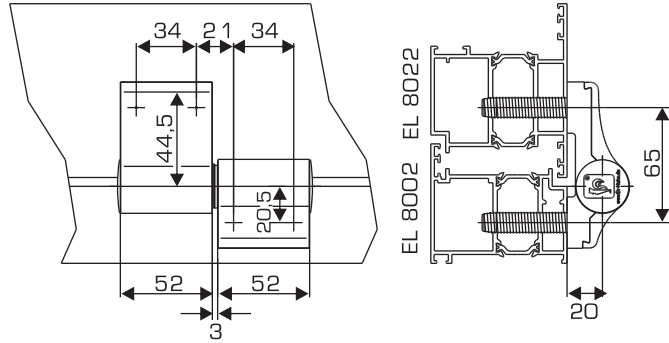

**Τοποθέτηση διπλού μεντεσέ TURBAND 4
σε είσοδο ανοιγόμενη προς τα έξω**
**Placing a double TURBAND 4 hinge
to an outwards opening entrance**

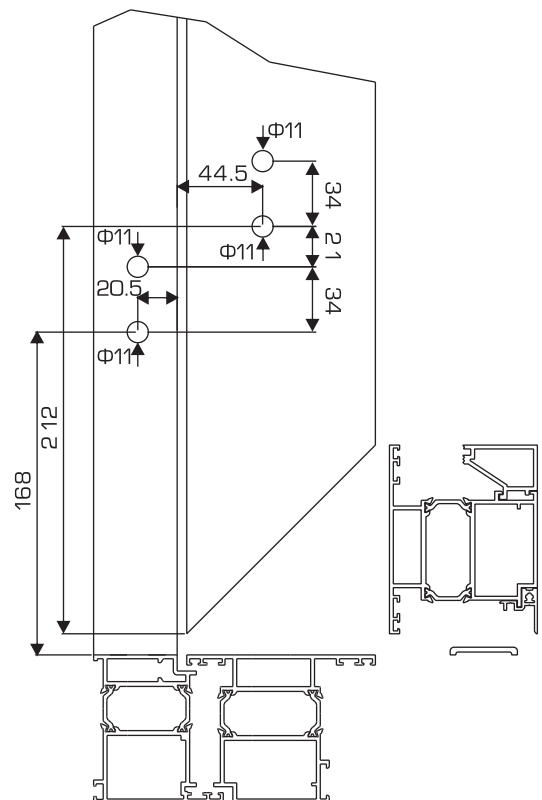
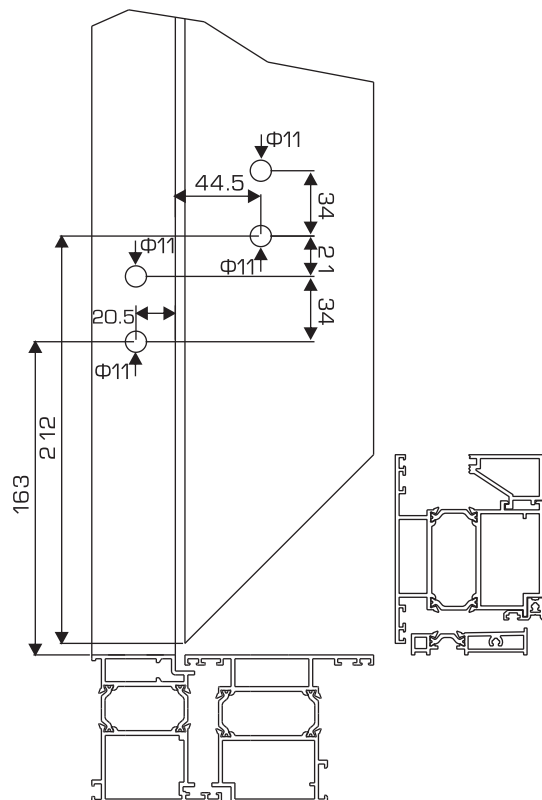
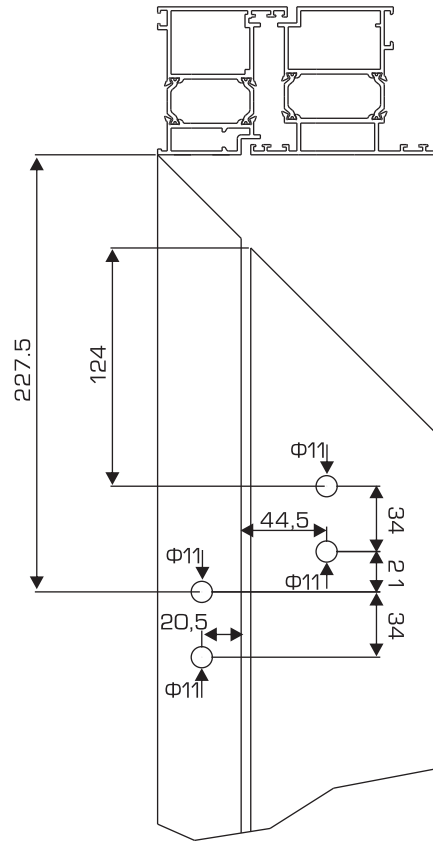
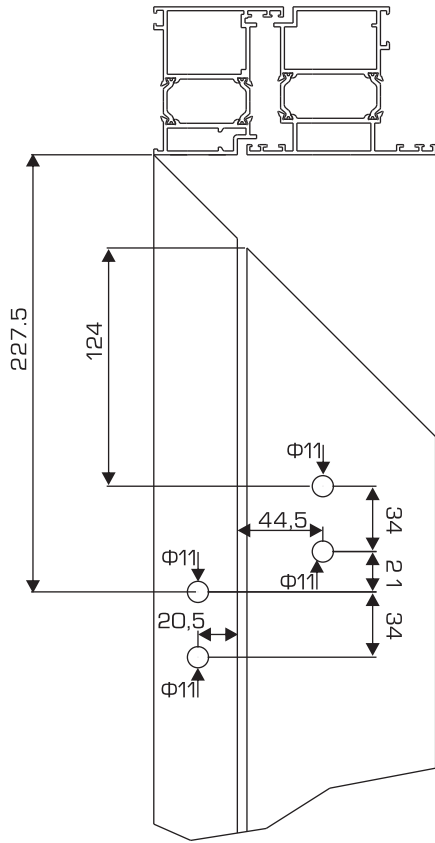

Αποστάσεις κατεργασίας για
τριπλό μεντεσέ TURBAND 4 για είσοδο
ανοιγόμενη προς τα έξω με ανεμοφράκτη
Dimensions for triple TURBAND 4
hinge for an outwards
opening door with windshield

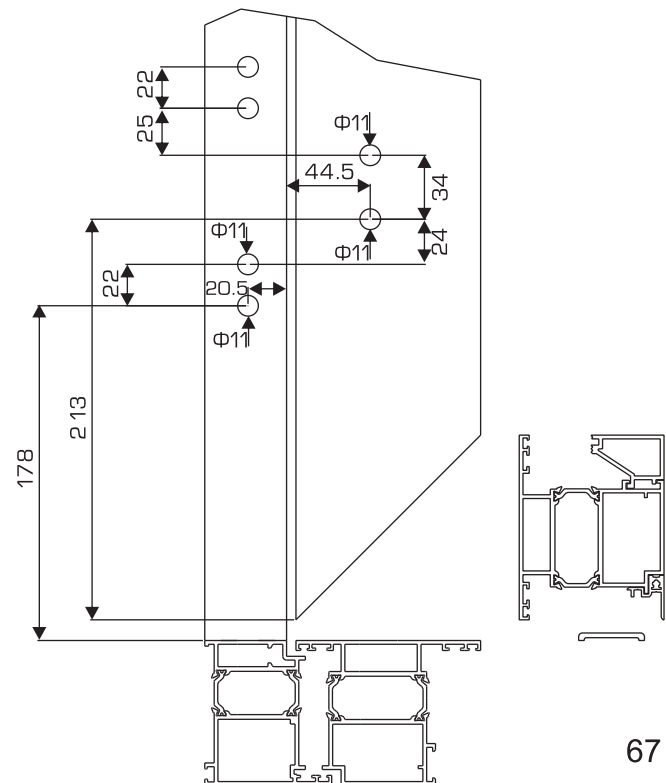
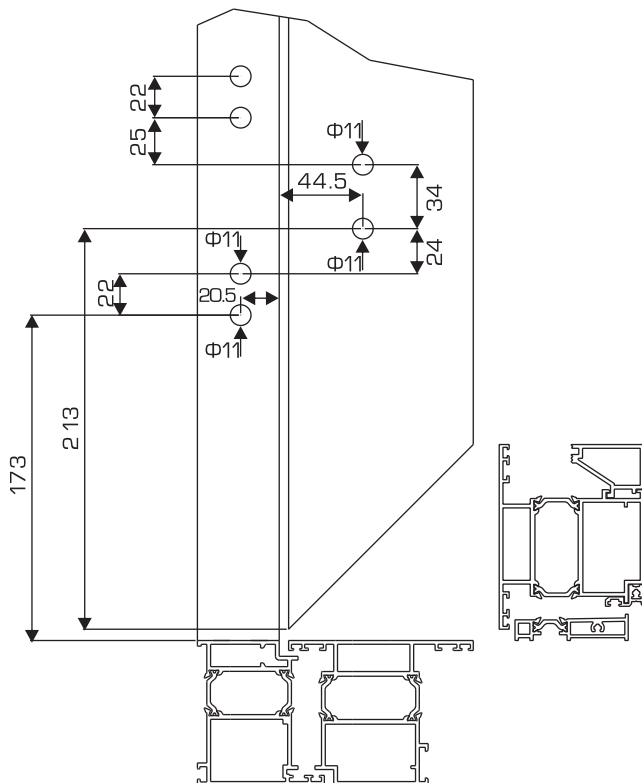
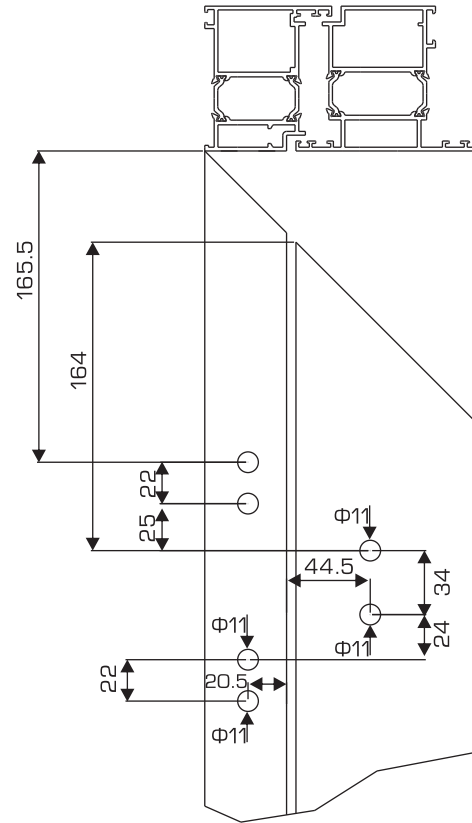
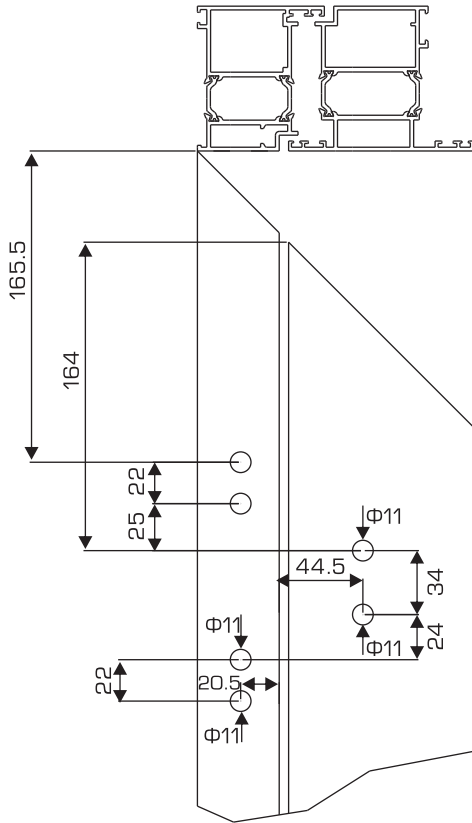

Απορροές
Drainage

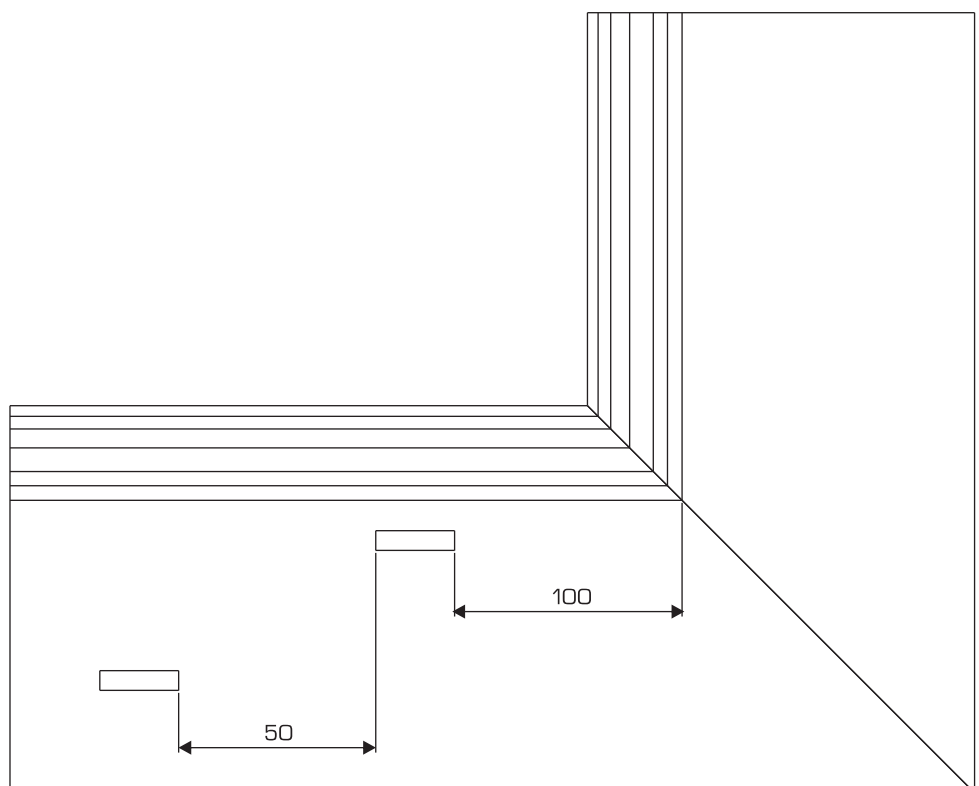
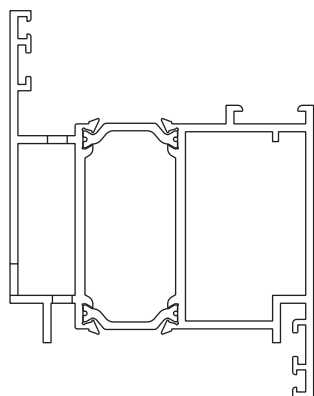
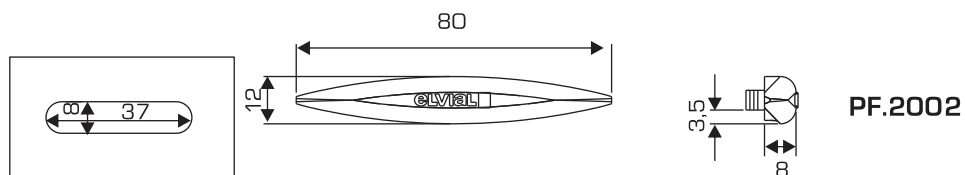
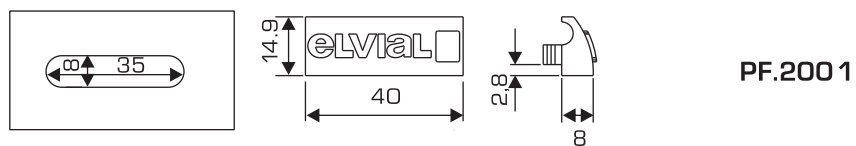
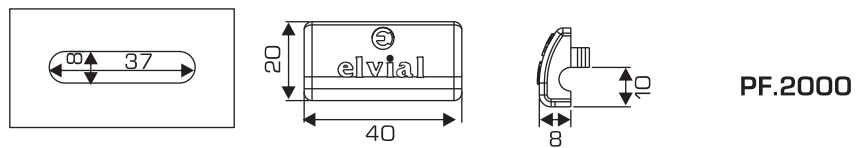

Απορροές για είσοδο ανοιγόμενη προς τα μέσα
Drainage for an inwards opening entrance

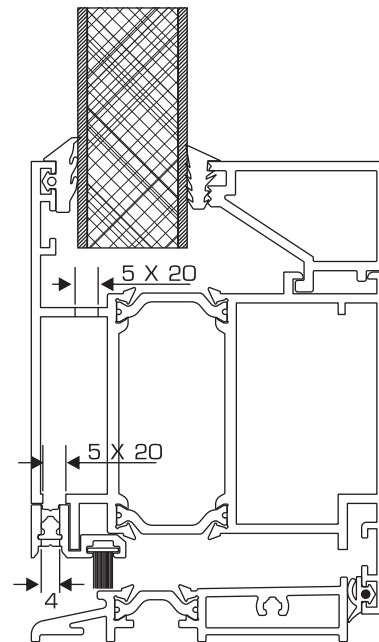
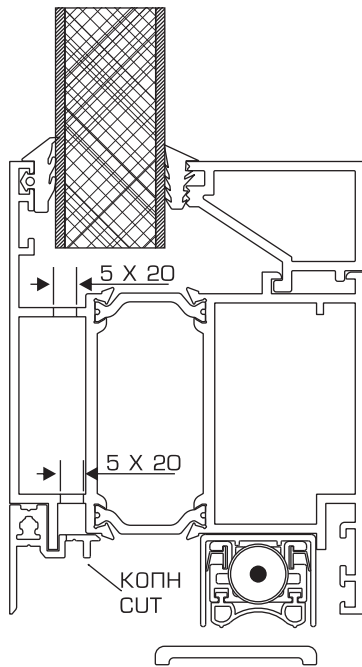

ή/or

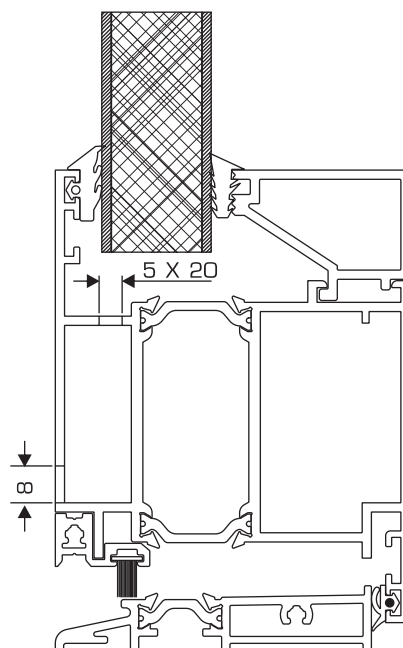
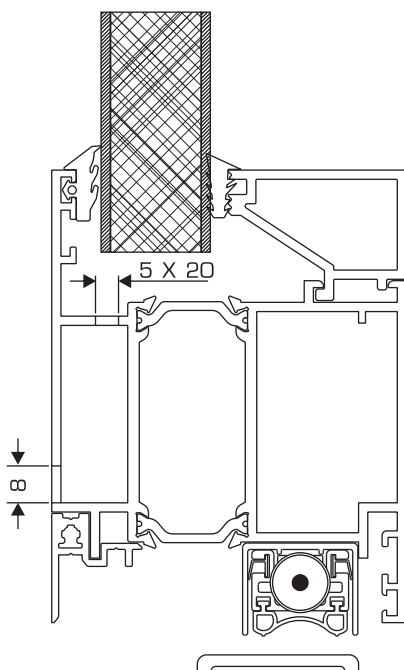

Απορροές για είσοδο ανοιγόμενη προς τα έξω
 Drainage for outwards opening entrances

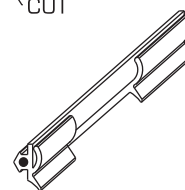
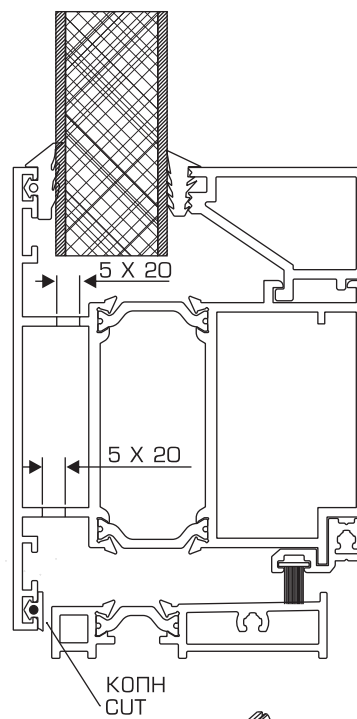
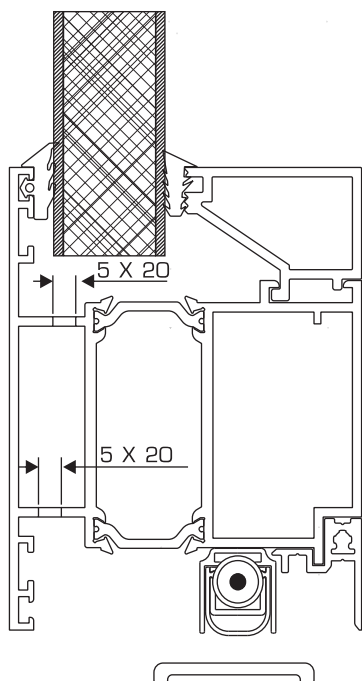

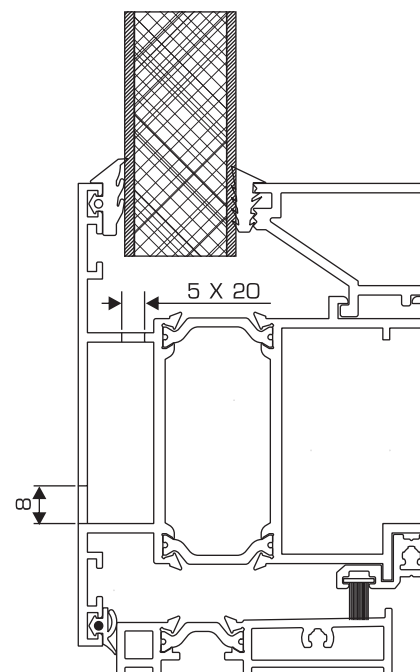

ή / or

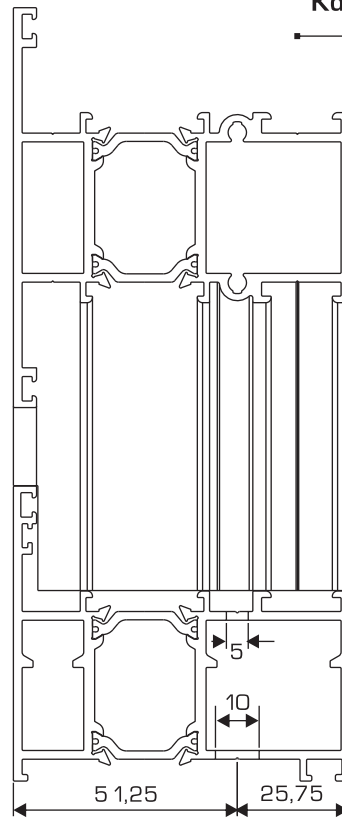
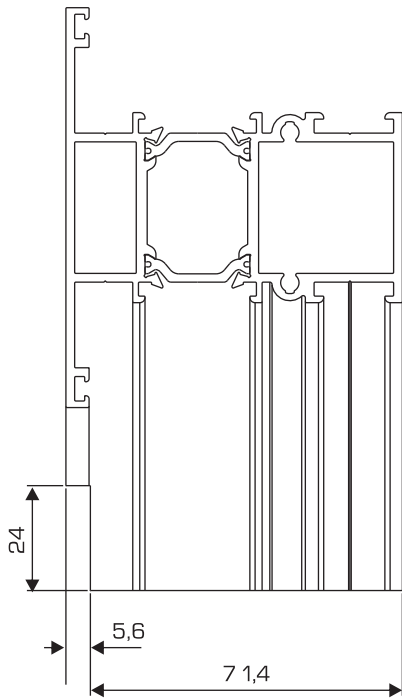

Κατεργασίες και τοποθέτηση Ταφ

Placing a "T" Profile



 ΒΙΔΑ/SCREW
 M 4,8X50
 DIN 798 1

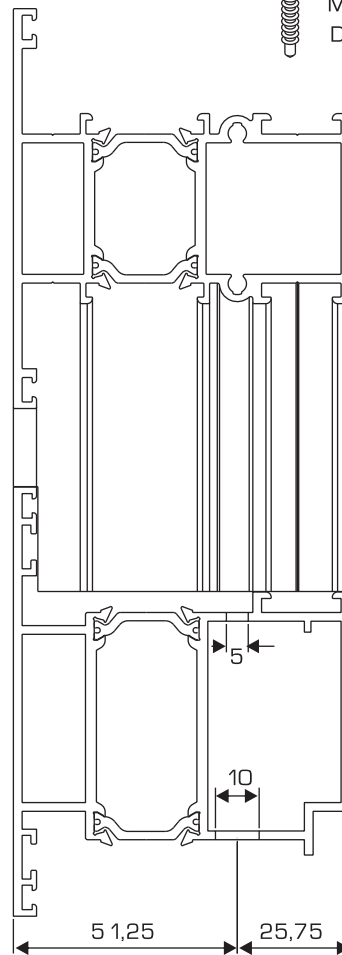
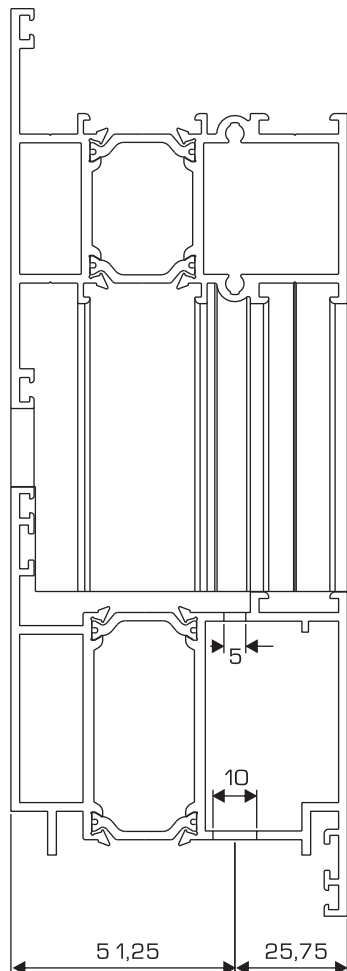

Τοποθέτηση ανεμοφράκτη
Placing a windshield

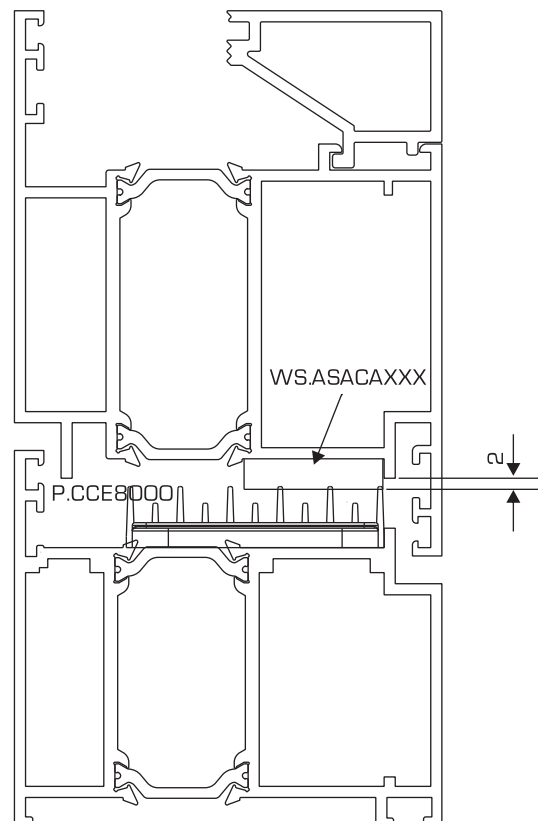
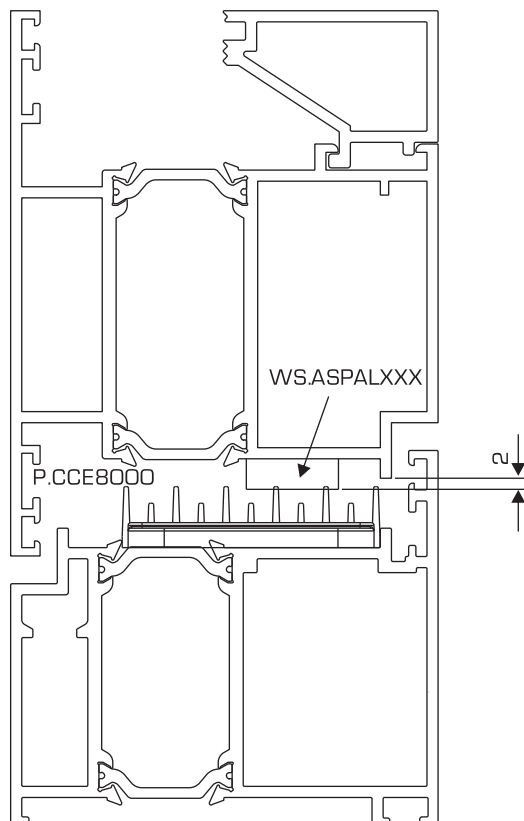
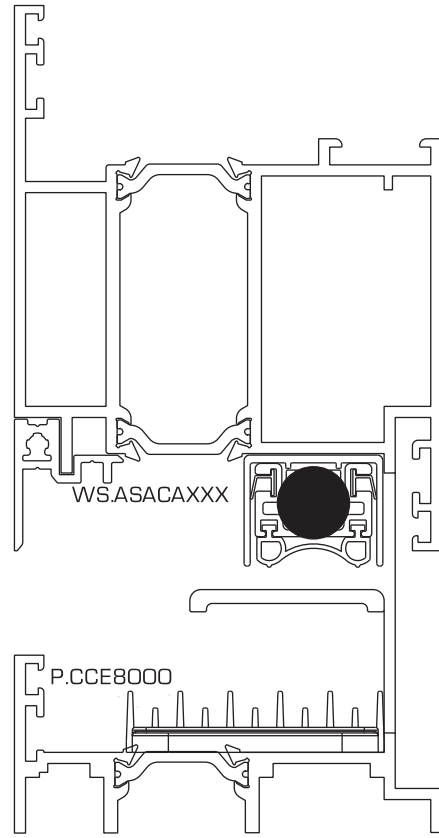
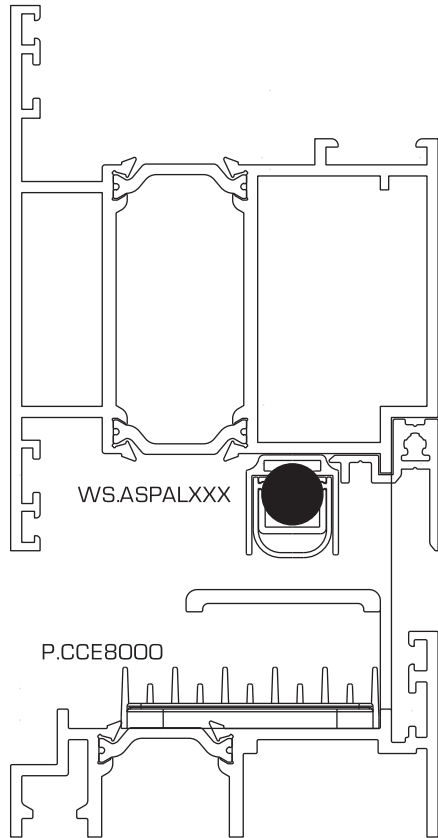

EL - 8000



■	Συνοπτικά προφίλ - Synoptic profiles
■	Προφίλ - Profiles
■	Τομές - Sections
■	Κοπές - Cuttings
■	Εξαρτήματα - Accessories
■	Κατεργασίες - Constructions' Specifications
■	3d's

Τοποθέτηση P. 8071 με κατωκάσι

Placing P. 8071 with threshold

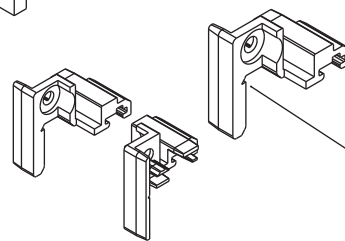
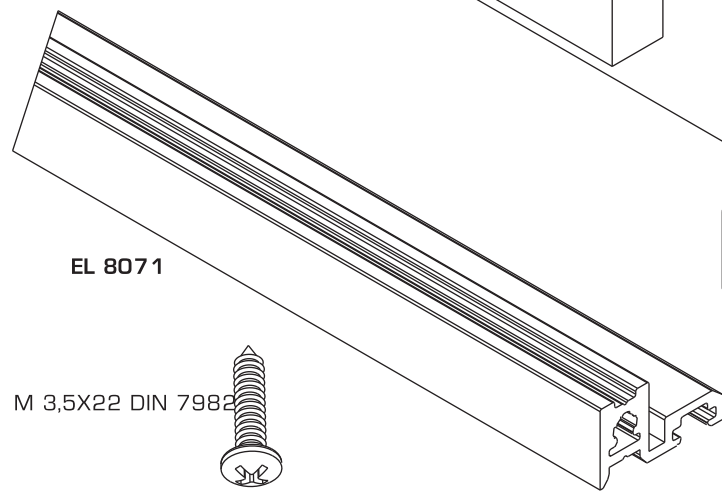
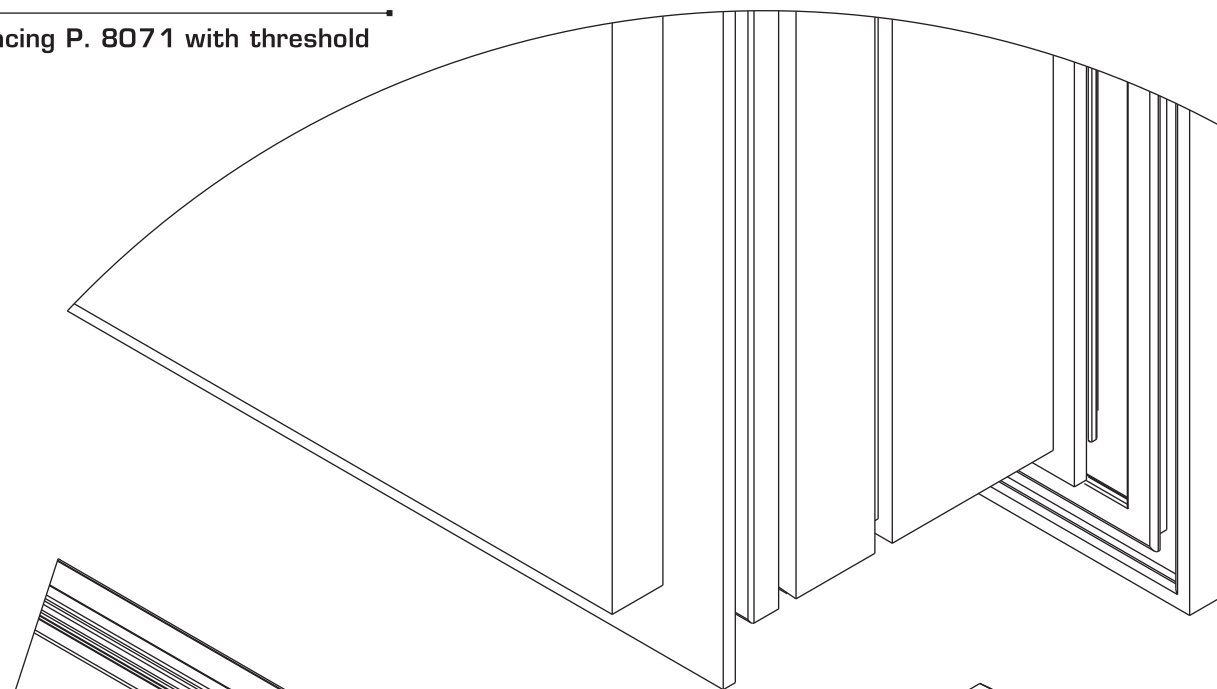

Όταν η τάπα P.8071 χρησιμοποιείται στο προφίλ EL 8071 την κόβουμε στο σημείο της εγκοπής

When the cover P.8071 is used with the profile EL 8071 it should be cut at the gap

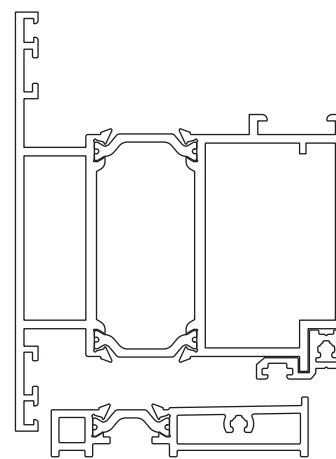
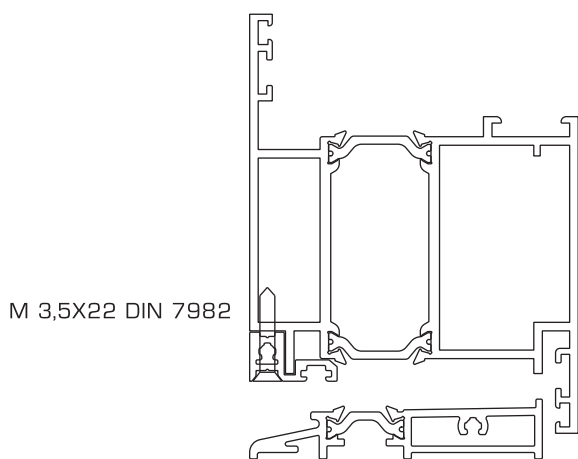
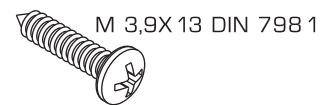
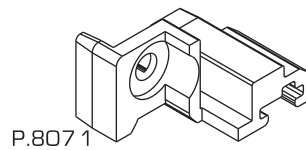

Τοποθέτηση P. 8071 με ανεμοφράκτη
Placing P. 8071 with windshield

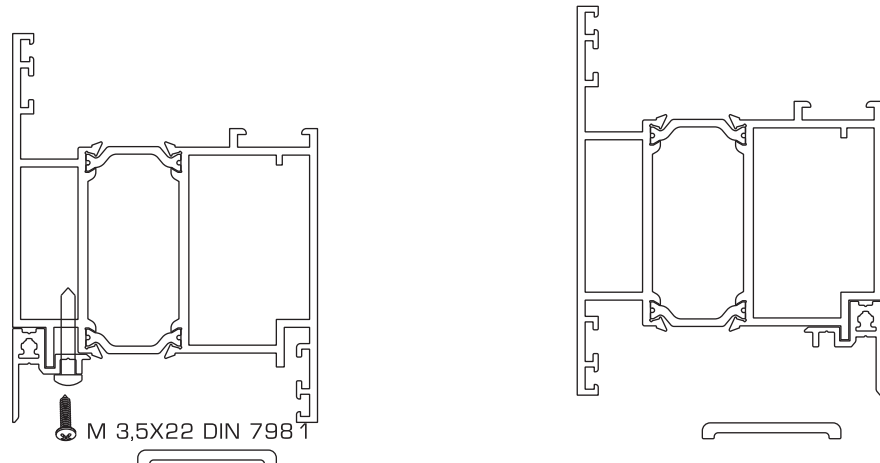
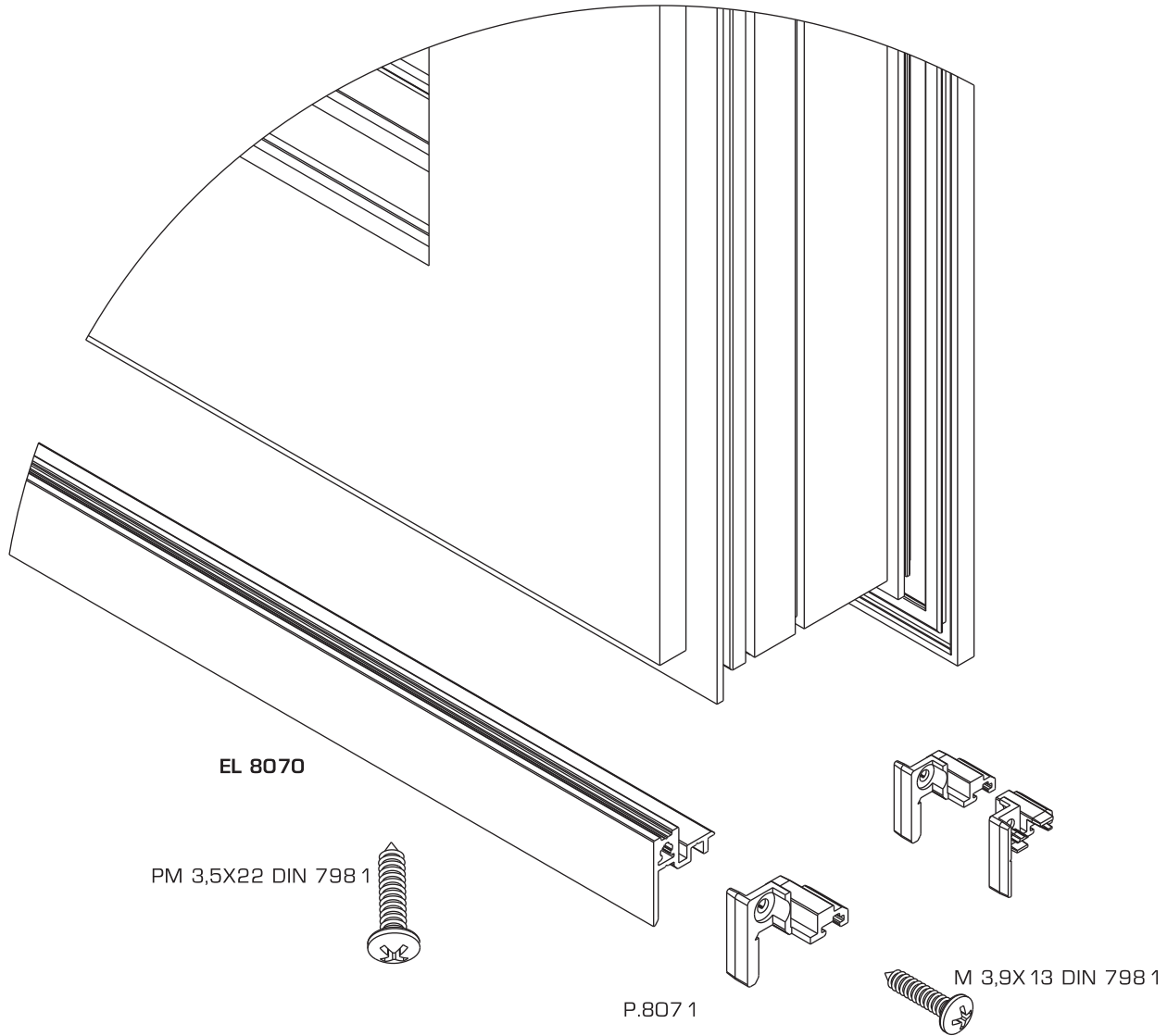

Τοποθέτηση P. 8076

Placing P. 8076

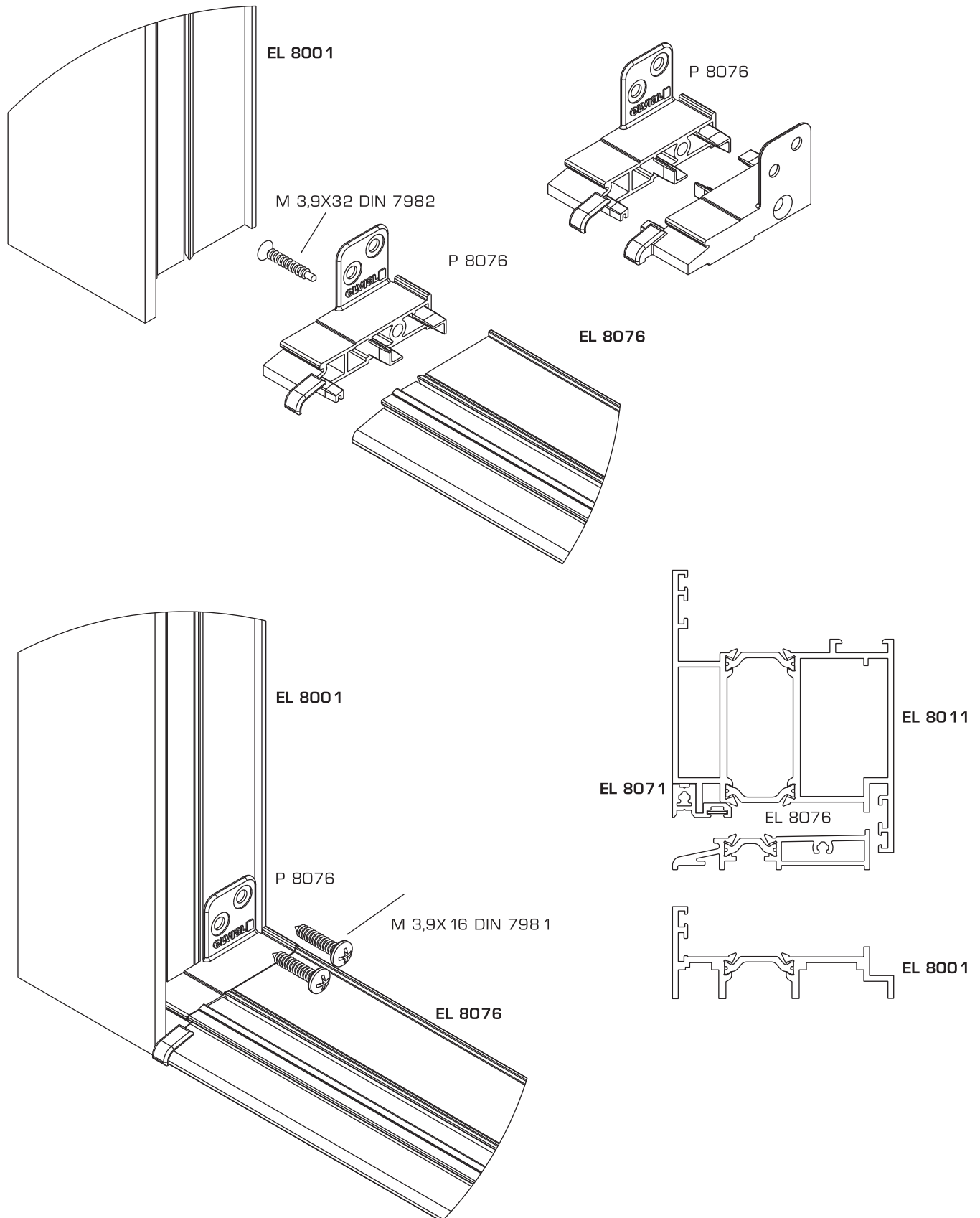

Τοποθέτηση P. 8077

Placing P. 8077

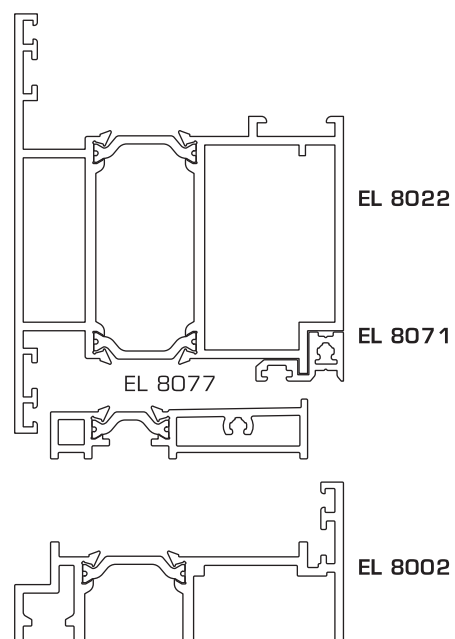
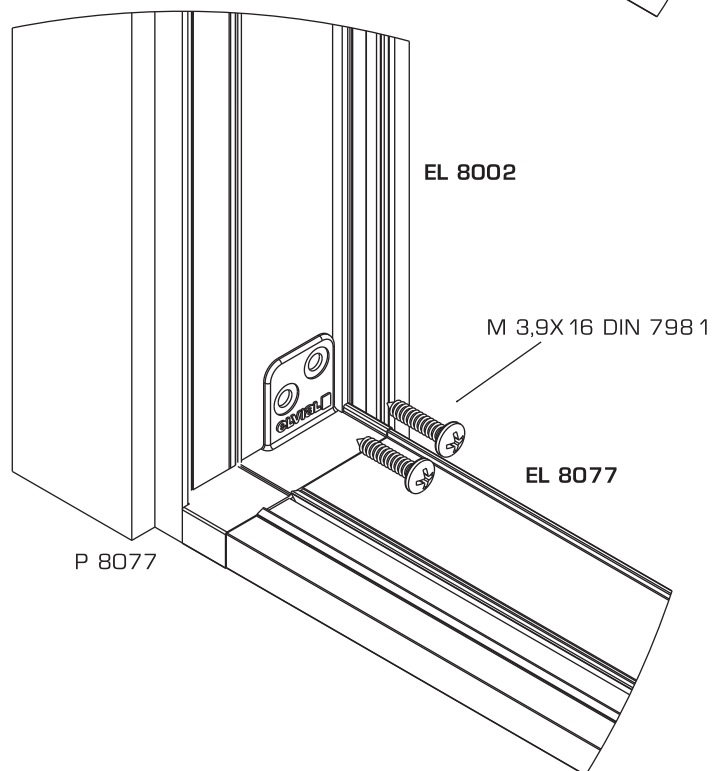
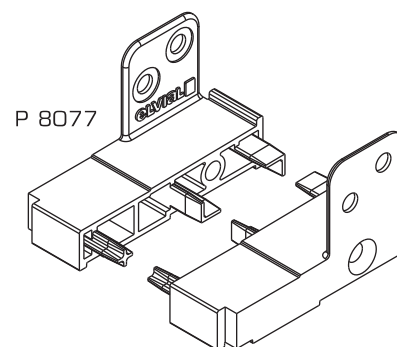
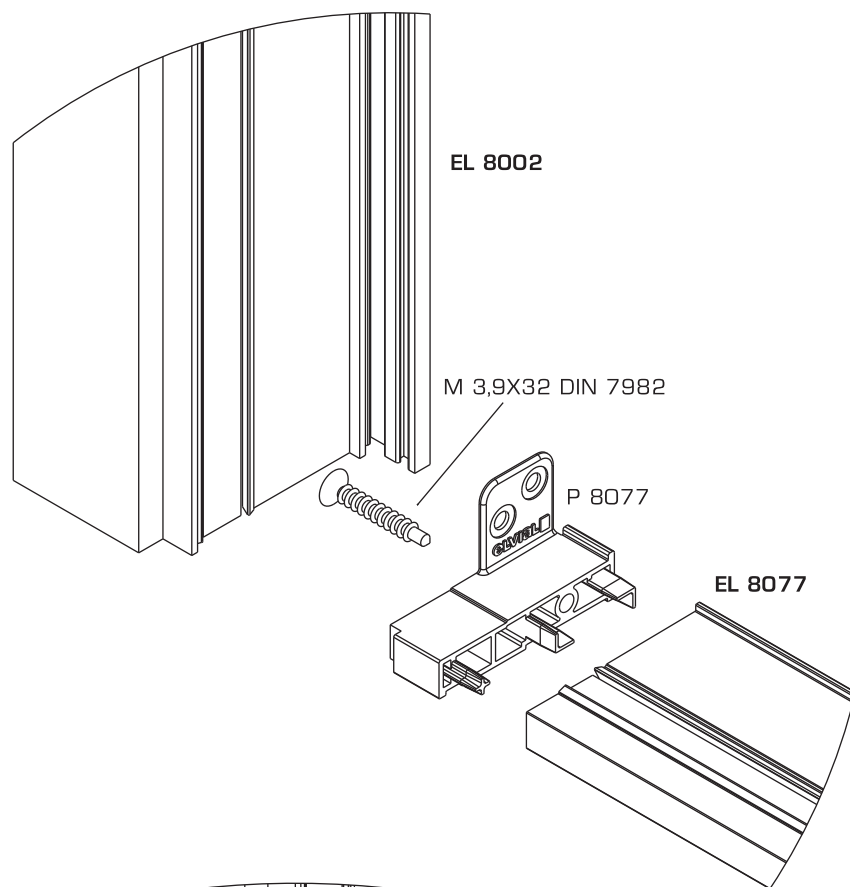

Τοποθέτηση P. 806 1XXX

Placing P. 806 1XXX

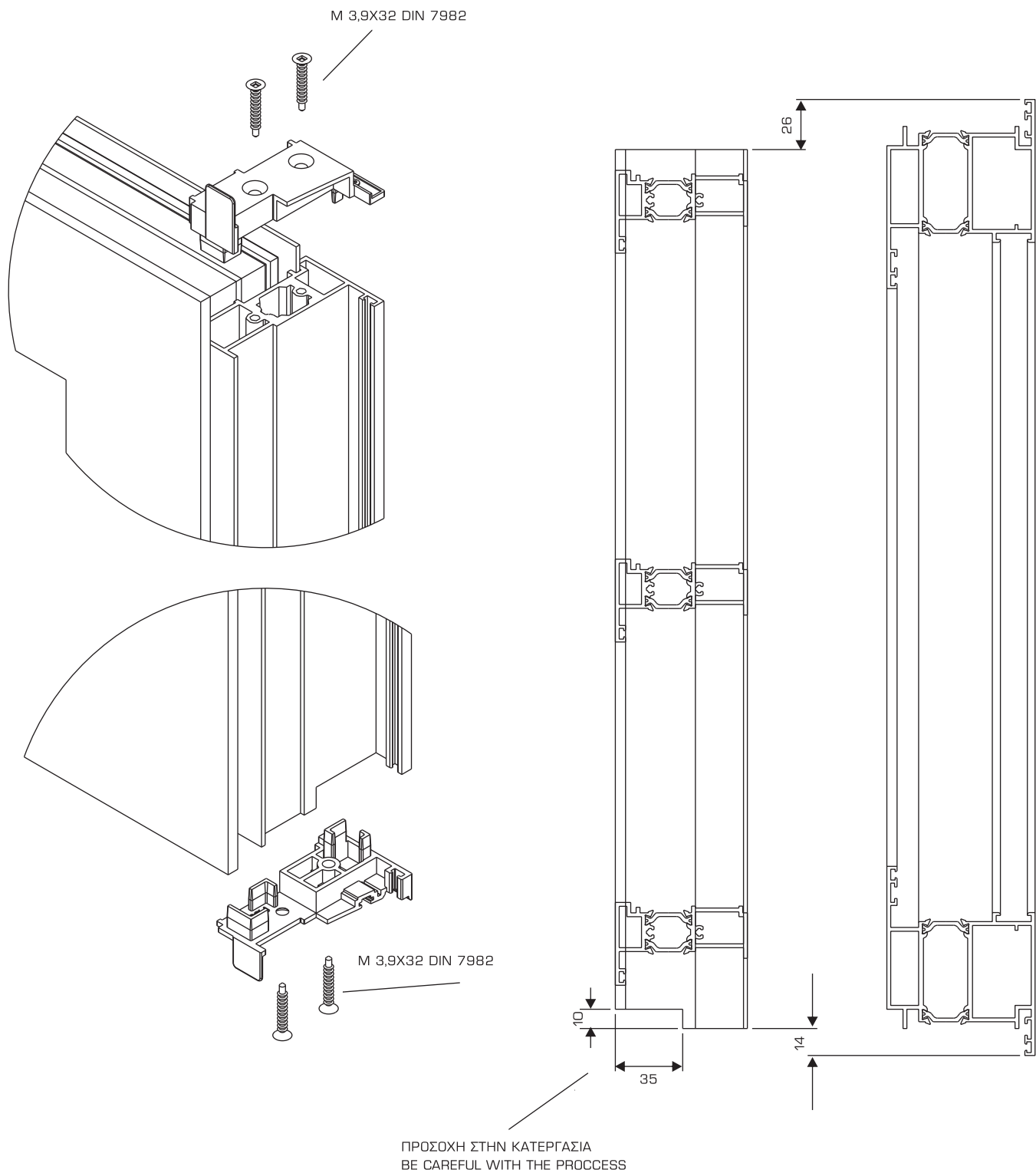

Τοποθέτηση P. 8062XXX

Placing P. 8062XXX

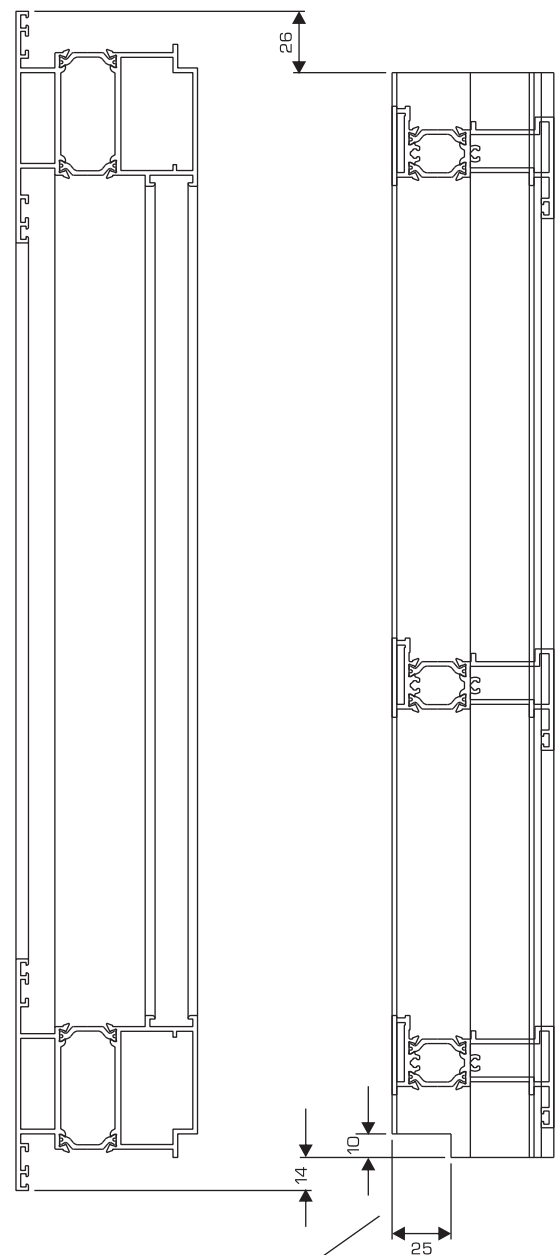
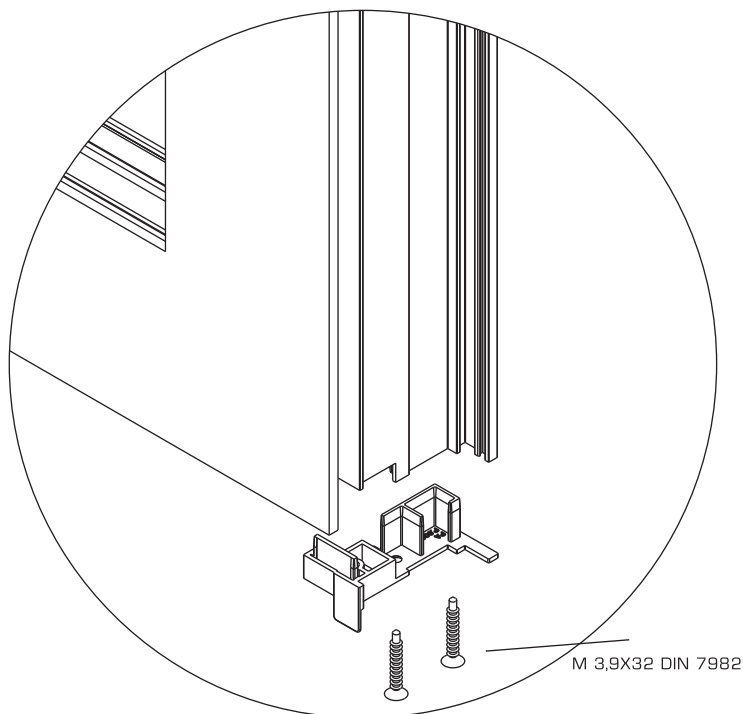
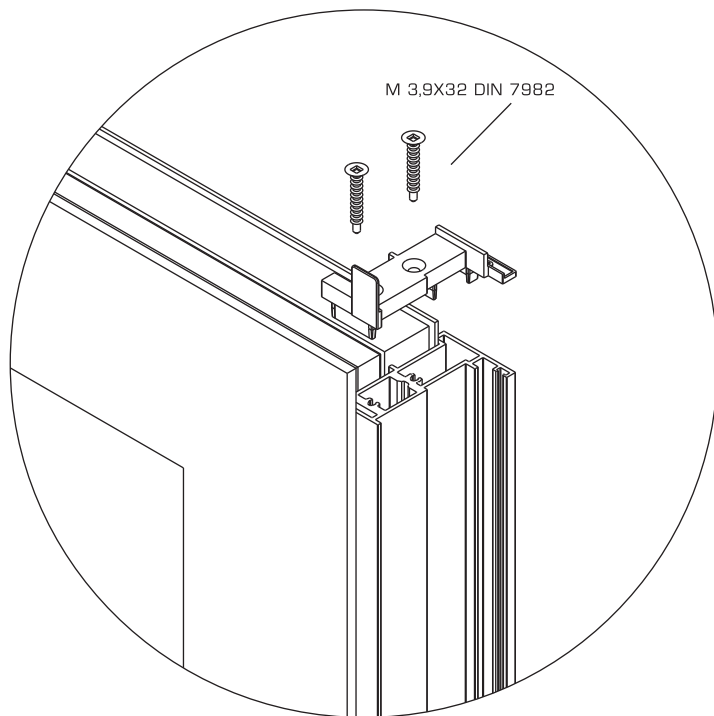

ΠΡΟΣΟΧΗ ΣΤΗΝ ΚΑΤΕΡΓΑΣΙΑ
BE CAREFUL WITH THE PROCESS

Τοποθέτηση συρτών

Placing latches

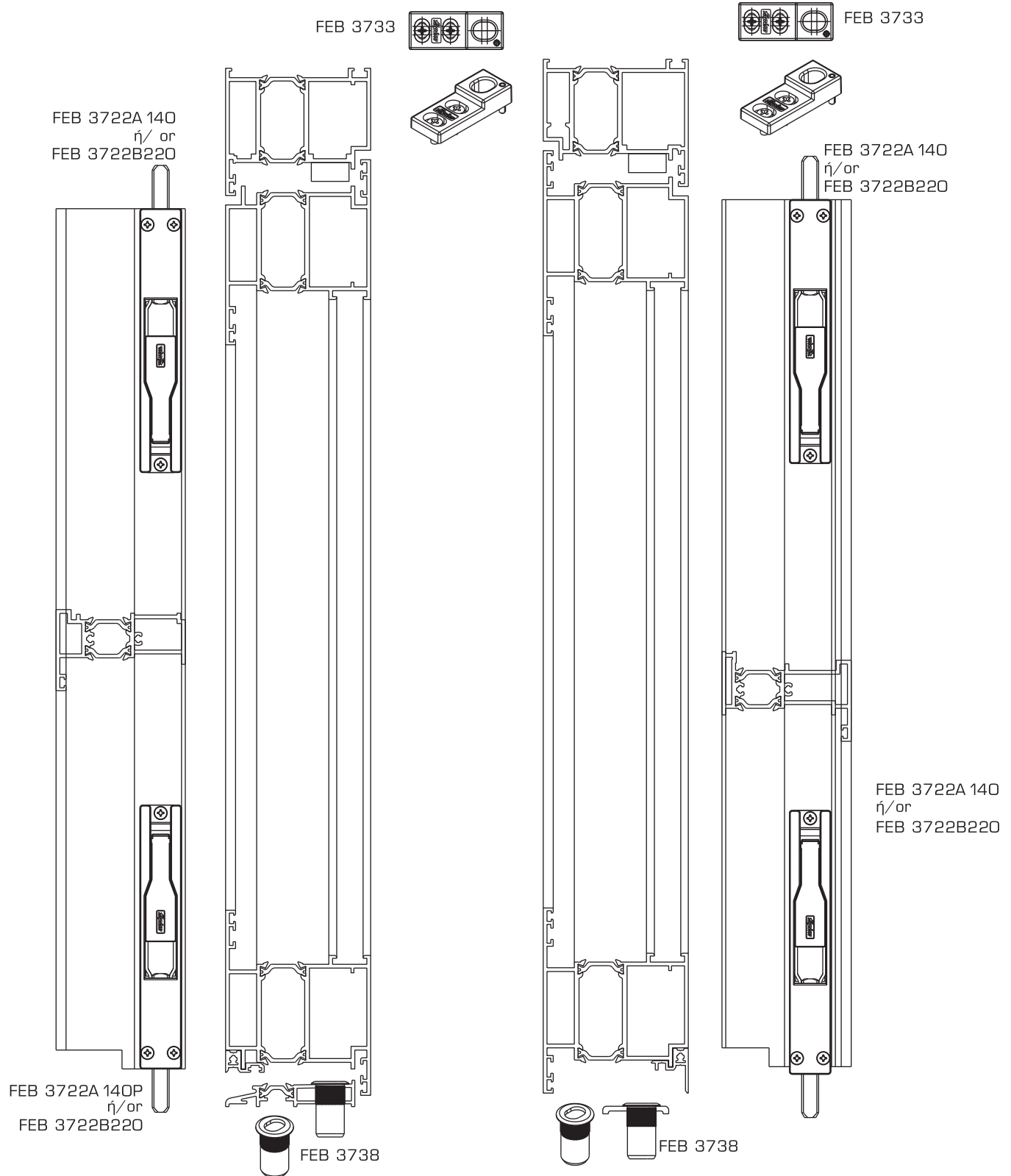



EN

GR

SR

elvial.gr

elvial-i2.eu

